



Electric Hydraulic Tensioning Pump with carrying handle



Electric Hydraulic Tensioning Pump with roll cage

Description

HYDAC Electric Hydraulic Tensioning Pump is a compact hydraulic power unit that has 2 functionalities (high pressure – low flow and high flow – low pressure) depending on the load, and it's built into the radial piston pump.

The unit comes with a manual directional control valve, a bleed down needle valve (to control lowering speed) and a remote pressure control valve. An optional roll cage or carrying handle are available upon request.

The power unit can be assembled with 6.5 litre hydraulic tank.

Applications

- Bolt tensioning
- Concrete reinforcement
- High pressure jacking
- Rescue tools.

Special features

- Custom designed manifold
- Bieri hydraulic components
- High / Low radial piston pump
- Pendant and local control on electric box.

Electric Hydraulic Tensioning Pump

Technical Specifications:

Tank size:	6.5 litre
Maximum working pressure:	700 bar
Flow at high flow stage:	~ 8 l/min
Flow at high pressure stage:	0.6 l/min
Supply power:	230 VAC 10Amp
Electric Motor:	1.1 kW 3 phase (using single phase in and 3 phase out inverter)
Hydraulic pump:	Two stage Bieri radial piston pump
Viscosity range:	12...220mm ² /s
Permitted operating fluid:	Mineral oils
Fluid temperature:	-10°C...+80°C
Ambient temperature:	-10°C...+50°C
Protection class:	IP65
Power cable length:	5 m
Suction filter:	Wire mesh strainer
Dry weight:	~ 27 Kg

SPECIAL FEATURES

- Custom designed aluminium manifold
- Built-in check valve in pressure line
- Built-in bleed down valve on service port
- Gauge port
- Filling and breather filter
- Visual level gauge
- Adjustable high pressure remote relief
- Optional roll cage or carrying handle

Hydraulic Circuit Diagram

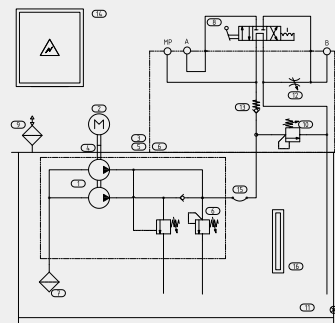

Model Code

HPU 6.5 1.1 230 5 700 R

High Pressure Tension Unit

HPU = High Pressure Unit

Tank size

6.5 litre

Motor size

1.1 kW

Power supply

230V 50Hz

Flow rate

5 LPM

Maximum Pressure

700 bar

Handling option

R = roll cage

H = handle

Omitted = no additional handle

Dimensions - HPU / 6.5 / ... / ... /

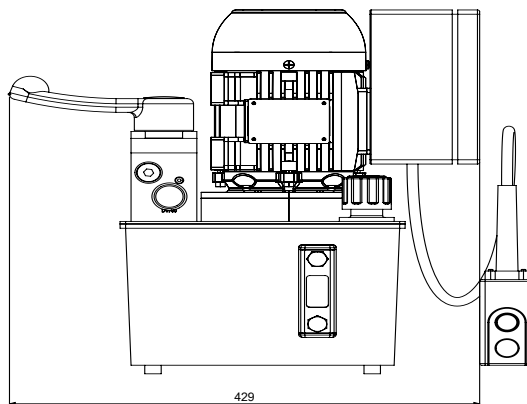
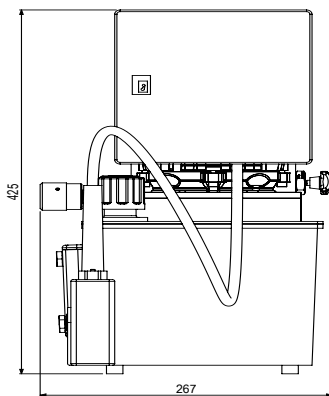
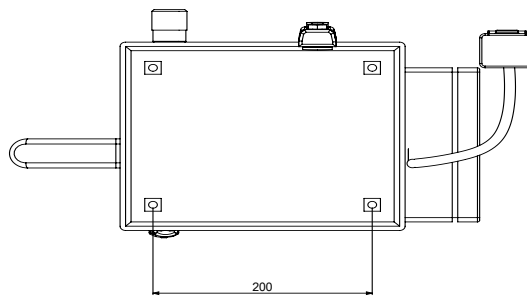

PART NUMBER	DESCRIPTION
2357517	HPU 6.5L 1.1kW 230V 50Hz 5LPM 700bar
2356671	HPU 6.5L 1.1kW 230V 50Hz 5LPM 700bar H
2357515	HPU 6.5L 1.1kW 230V 50Hz 5LPM 700bar R

Note

The information in this brochure relates to the operating conditions and applications described.

For applications and operating conditions not described, please contact the relevant technical department.

Subject to technical modifications.

HYDAC Australia / New Zealand

109-111 Dohertys Road
Altona North, VIC. 3025
Phone: (03) 9272 8999
info@hydac.com.au
www.hydac.com.au