

## Hydraulic Safety Control Unit HY-TTC 30SH

### General Description

The HY-TTC 30SH is a compact control unit specially developed for use in cost-sensitive applications or smaller machines. The device is based on an Infineon XC22xx microcontroller and supports programming in C. With its 28 freely configurable I/Os it can be operated with a wide variety of sensors and actuators.

The HY-TTC 30SH was developed following the international standard EN ISO 13849 and is certified by TÜV NORD. It meets the requirements of Functional Safety according to Performance Level (PL) c.

The 30SH version is best suited to controlling proportional functions in safety applications. Six out of the eight PWM outputs have integrated current measurement which means that, for example, up to three hydraulic axes can be current controlled. The HY-TTC 30SH was specially developed for vehicles and machines used in rugged operating environments and at extreme operating temperatures. The device is protected by a proven, robust and compact housing, specially designed for the off-highway industry.

### Specifications

Parameter		Unit
ECU Dimensions	147 x 92 x 38	mm
Dimensions for Minimum Connector Release Clearance	208 x 92 x 38	mm
Weight	330	g
Connector	48	pins
Operating Temperature	- 40 to + 85	°C
Operating Altitude	0 to 4000	m
Supply Voltage	8 to 32	V
Peak Supply Voltage	40	V <sub>max</sub>
Max Idle Current	≤120	mA
Standby Current	≤1	mA
Total Load Current	24	A <sub>max</sub>
<b>Standards</b>		
Functional Safety	EN ISO 13849 PL c	
CE-Mark	2014/30/EU 2006/42/EC	
E- Mark	ECE-R10 Rev.4	
EMC	EN 13309 ISO 14982 CISPR 25 EN 61000-6-2/-4	
ESD	ISO 10605	
Electrical	ISO 16750-2 ISO 7637-2,-3, limited to 40 V by external load dump protection	
Ingress Protection	EN 60529 IP67 ISO 20653 IP6k9k	
Climatic	ISO 16750-4	
Mechanical	ISO 16750-3	



### Features

#### CPU Core

- Infineon XC22xx 16/32 bit CPU running at 80 MHz
- 768 kByte int. Flash, 82 kByte int. RAM, 8 kByte EEPROM

#### Interfaces

- 1 x CAN, 125 kbit/s up to 1 Mbit/s,
- 1 x CAN bus termination configurable via connector pins

#### Outputs

- 6 x PWM OUT or digital OUT, up to 3 A, high side switch with current measurement, overload and open load detection, PL c capable  
alternative use  
digital timer IN (10 Hz - 10 kHz) or analog IN 0 - 32 V both with integrated Pull-Up
- 2 x PWM OUT or digital OUT, up to 3 A, high side switch with overload detection, open load detection and support for high inrush current loads, PL c capable  
alternative use  
digital timer IN (10 Hz - 10 kHz) or analog IN 0 - 32 V both with integrated Pull-Up
- 2 x digital OUT, up to 3 A, low side switch  
used as redundant switch-off path for high side PWM outputs
- 6 x PVG OUT  
15 % - 85 % BAT+ with PVG valves  
alternative use  
voltage OUT 0 V - 75 % BAT+ with 10 kOhm low side load or analog IN 0 - 32V

#### Inputs

- 4 x digital timer IN (0.1 Hz - 10 kHz), PL c capable if used in pairs  
alternative use  
analog IN, 0 to 32V  
1x rotary encoder  
configurable Pull-Up/Down in digital IN mode
- 2 x analog IN, configurable in software, input functions are PL c capable if used in pairs  
0 - 5V / 10 V IN      0 - 25 mA IN  
0 - 65 kOhm IN      up to 25 mA LED control OUT
- 6 x analog IN, configurable in software, input functions are PL c capable if used in pairs  
0 - 5V / 10 V IN      0 - 25 mA IN  
up to 25 mA LED control OUT
- 2 x analog IN 0 - 32V, PL c capable if used in pairs  
configurable Pull-Up/Down in digital IN mode

#### Other

- 1 x sensor supply 5 V, 100 mA
- Internal monitoring of board temperature, sensor supply, K15 input and battery voltage

#### Software

- Programming: Board support package and driver library available for programming in C

All I/Os and interfaces are protected against short circuit to GND and BAT+ and can be configured by software.

All analog inputs use 10 bit resolution.

All analog voltage inputs can be used as digital inputs with configurable switching levels and hysteresis.

Dedicated power supply pins for high side outputs.

For safety functions two PL c capable inputs of the same type have to be used in parallel to provide redundancy in case of a failure.

Details to the standards can be found in the user manual.

**Block Diagram**

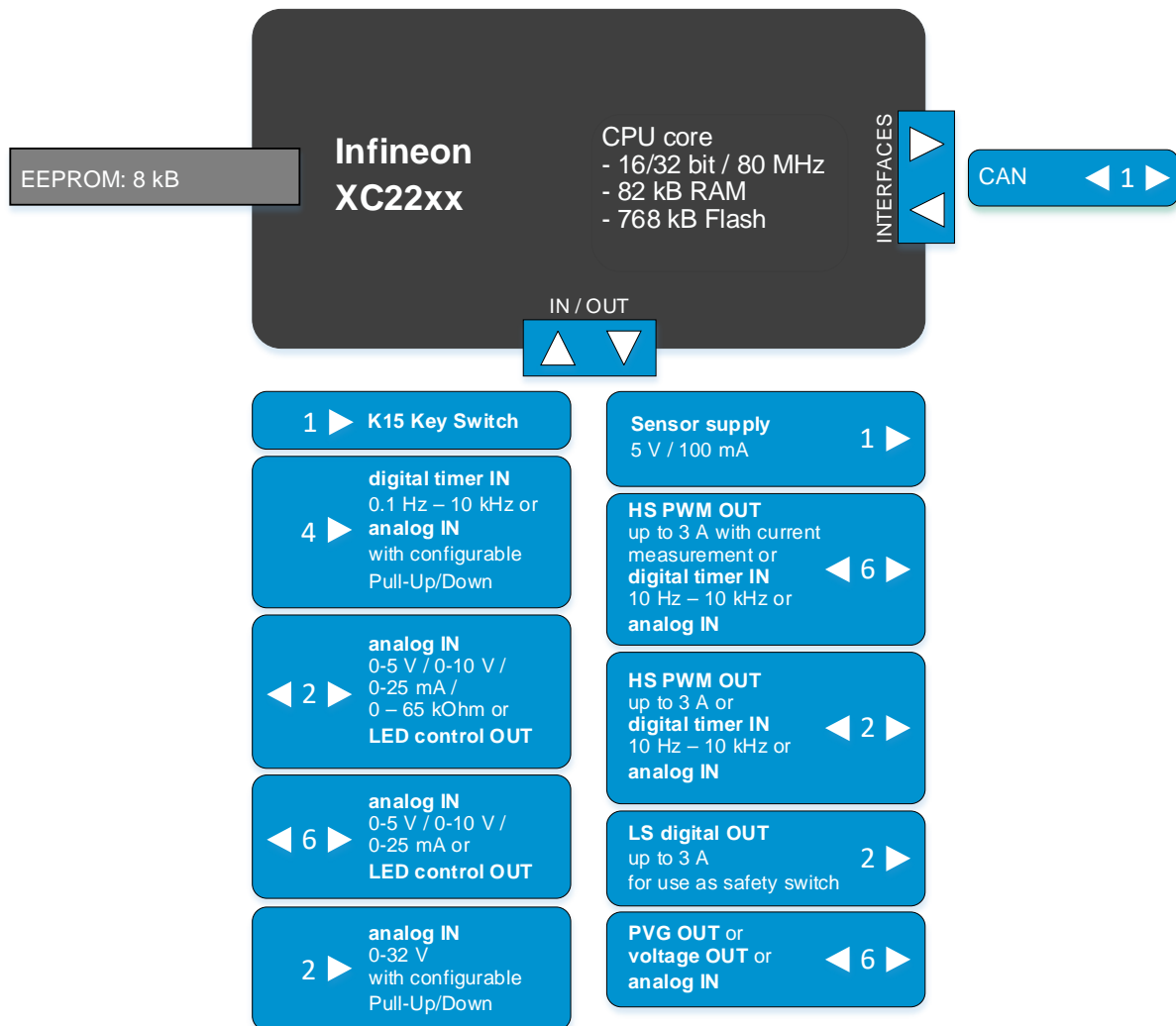

**Housing and Connector**

Aluminum die-cast housing

48-pin connector, 1 connector chamber

Mating connector: FCI PPI0001494 or PPI0001495  
Molex 64320-1311 or 64320-3311

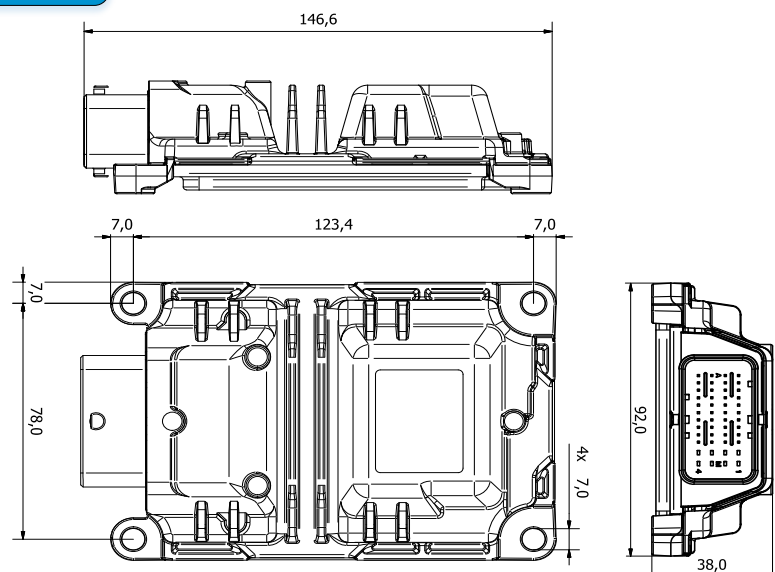

For further information, including price and availability, please contact [products@ttcontrol.com](mailto:products@ttcontrol.com).

Subject to changes and corrections. HY-TTC 30SH is a product name of TTControl GmbH. Other trademarks are the property of their respective holders. To the extent possible under applicable law TTControl hereby disclaims any and all liability for the content and use of this product flyer.