

## HY-eVision<sup>2</sup> 7.0, Optically Bonded

### Description

This compact 7.0" monitor with built-in, high-end Vision<sup>2</sup> display controller provides maximum performance under extreme environmental conditions and is therefore perfectly suited for use in off-highway vehicles. The unit may either be mounted in the vehicle dashboard or through a RAM ball elsewhere in the vehicle cockpit in portrait or landscape orientation. It offers full IP 65 protection. The display is characterized by low reflection and high color saturation and provides optimal readability in any lighting conditions due to optical bonding of cover lens to the LCD. Ten programmable control keys allow the creation of an easy-to-use human machine interface. Up to two cameras can be connected that give the operator an optimum view around the vehicle.

### Specifications

Display diagonal size	7.0" (17.8cm) 16:9 aspect ratio
Dimensions	235(W) x 135(H) x 52.7(D) mm
Weight	1.15 kg
Resolution	800 (W) x 480 (H) pixel
Active area	152,4 (H) x 91,44 (V) mm
LCD type	TFT (thin film transistor) active matrix
Backlight	LED
Backlight lifetime	50.000 hours
Housing	Robust housing with aluminium front

### Optical Characteristics

Luminance	500 cd/m <sup>2</sup>
Viewing angle	V = -60 / + 60 deg H = -70 / + 70 deg
Contrast ratio	600:1

### Maximum Ratings

Operating temperature	-30 to +60°C (ambient)
Storage temperature	-30 to +80°C
Supply voltage	9 to 32V

### Standards

CE-Mark	2014/30/EU
E- Mark	ECE-R10
EMC	EN 13309
ESD	ISO 10605
Electrical	ISO 16750-2 ISO 7637-3
Ingress Protection	ISO 20653 IP6k5
Climatic	ISO 16750-4
Mechanical	ISO 16750-3



### System Components

- Freescale i.MX51x application processor 32bit ARM Cortex A8 800MHz
- 1 GB Flash; 512 MB RAM
- RTC buffered by supercapacitor
- Membrane keyboard with 10 freely programmable buttons with backlight
- Auto-dimmable display backlight via ambient light sensor
- Internal temperature sensors for ambient and CPU temperature
- Panel or cabin mount, landscape or portrait orientation
- Cover lens optically bonded to the LCD

### Interfaces

- 2 x video input for external composite video cameras
- 2 x CAN (optional 4 x CAN), 125 kbit/s up to 1 Mbit/s
- 1 x RS-232 and 1 x Ethernet 100 Mbit/s
- 1 x USB 2.0 (Host)
- K15 for ignition input
- Wake-up Pin

### Software

- Programmable in CODESYS<sup>®</sup> V3 with enhanced target visualization, including support for CANopen<sup>®</sup> master
- Display of .pdf-files and animations
- Picture-in-Picture functionality
- Sleep Mode - wake-up to full operation within less than half a second

Reverse polarity protection and protection of all external interfaces (except USB) against short circuit to GND and BAT+.

**Block Diagram**

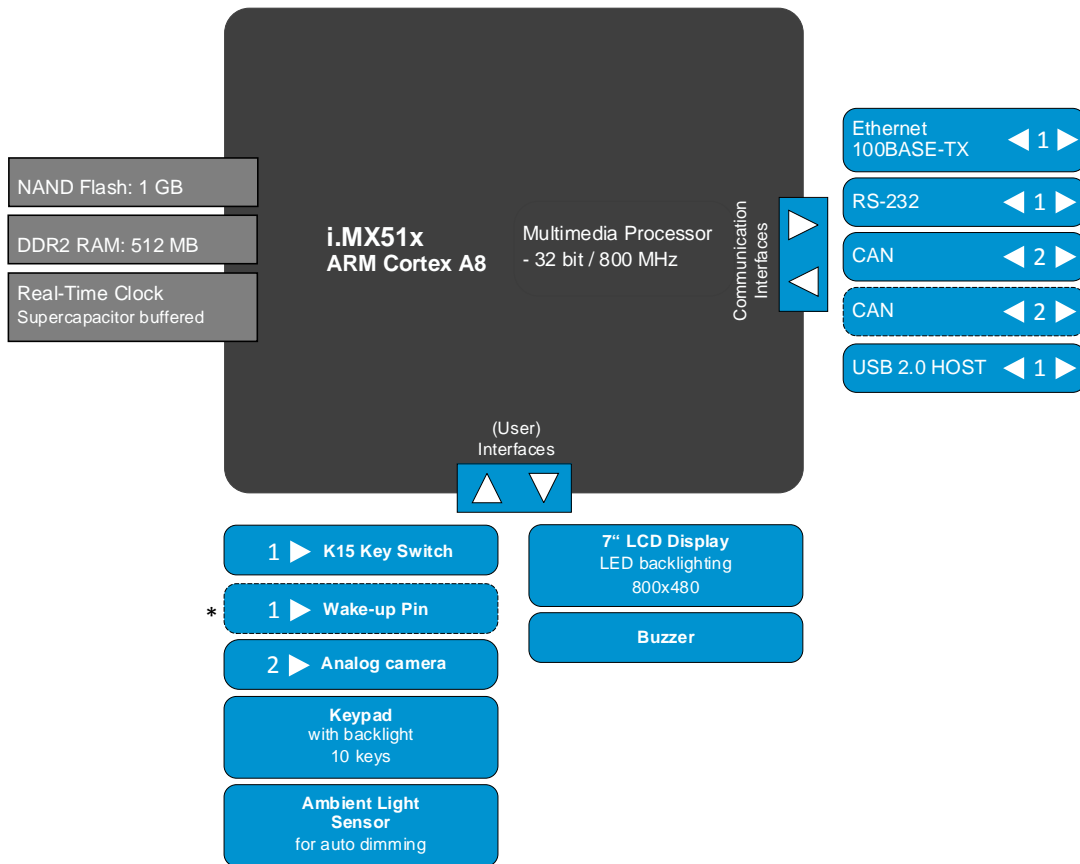

\*on 2 x CAN variant only

Optional

**Panel cut-out, housing back-side and side view with dimensions**

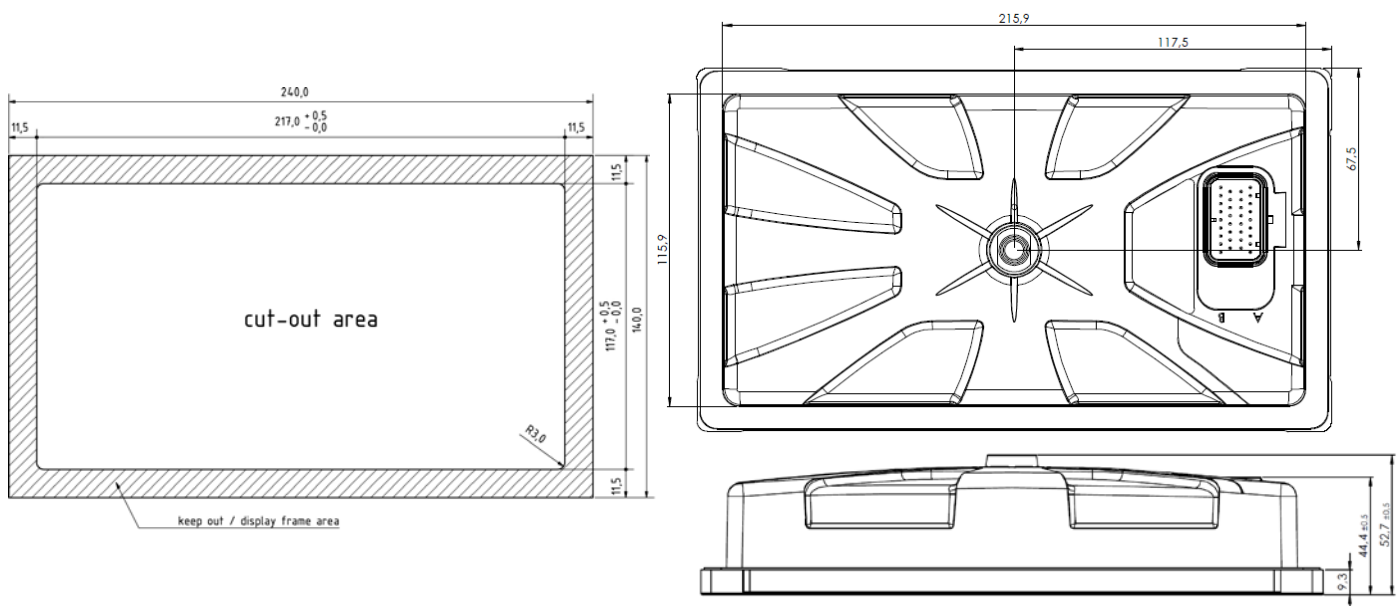

Subject to changes and corrections. HY-eVision<sup>2</sup> 7.0 is a product name of TTControl GmbH. CODESYS is a trademark of 3S Smart Software Solutions GmbH. All other trademarks are the property of their respective holders. To the extent possible under applicable law TTControl hereby disclaims any and all liability for the content and use of this product flyer.