

Hybrid filter AutoFilt® TwistFlow Strainer ATF

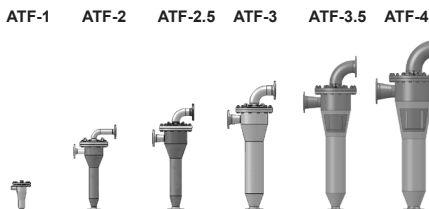

Specifications	
Nominal size:	G 1" – DN 200
Q _{s max.} :	400 m³/h
p _{s max.} :	16 bar
Filtration ratings:	Dependent on particle nature and operating conditions

1. GENERAL

Product description

- Coarse separation by centrifugal force with guaranteed filtration ratings
- Separation of solids from water and water-based media
- 2-stage operating principle:
 - Stage 1:** centrifugal separation
 - deals with high contamination loads
 - Stage 2:** conical filter element
 - guarantees effective filtration

Filter element technology

Even particles <100 µm are separated effectively, depending on their specific weight (see separation performance table) Whereas with conventional hydrocyclones under changed operating conditions there is the risk of dirt reaching the clean side, the wedge wire filter element in the AutoFilt® ATF performs a protective function (safety filter) with defined filtration ratings and thus prevents dirt from reaching the clean side.

- Conical filter element
- Wedge wire* 200 to 3000 µm
- Optional SuperFlush non-stick coating

Product advantages

- Suitable for wide variability in the quality of untreated water
- Copes easily with high contamination loads
- Degree of separation associated with a centrifugal separator combined with defined filtration rating
- No carry-over of contamination to the clean side
- Consistent quality of filtrate
- No rotating parts
 - Easy to service and low-maintenance
- For higher flow rates, also available as a system solution

*Please observe the filter material restrictions for particular sizes in acc. with model code.

Technical specifications of standard models

Size	p _{s max.} [bar]			Connector inlet/outlet	Connector cleaning line	Weight [kg]	Volume [l]	Filter area [cm²]	T _{s max.} [°C]
	PN6	PN10	PN16						
1			●	G 1"	G 1"	15	1.8	150	90
2	●	●	●	DN 50	DN 50	60	13.5	360	
2.5	●	●	●	DN 80	DN 80	135	28	966	
3	●	●	●	DN 100	DN 100	200	55	1720	
3.5	●	●	●	DN 150	DN 100	263	130	3500	
4	●	●	●	DN 200	DN 150	418	230	3900	

Filtration performance

Efficiency / particle size	Specific weight 7.5 g/cm³	Specific weight 2.6 g/cm³	Specific weight 1.7 g/cm³
> 100 µm	99%	98%	77%
100–75 µm	92%	84%	35%
75–50 µm	87%	78%	21%



AutoFilt® ATF system solution for filtering larger flow rates

2. FUNCTION

SPECIAL FEATURES

- Suitable for wide variability in the quality of untreated water and large contamination loads
- Hybrid system combining centrifugal separator and inline filter
- Degree of separation associated with a centrifugal separator combined with defined filtration rating
- No carry-over of contamination to the clean side
- Consistent quality of filtrate
- Specially developed conical filter elements provide optimum flow conditions
- Permanent self-cleaning of filter
- Low pressure loss – particularly in comparison with conventional centrifugal separators of a similar size
- Cleaning achieved by cross-flow with unfiltered fluid – no additional fluid is required
- Space-saving and compact
- On sizes 2 to 4, it is possible to replace the filter element without having to open the container.
- 2-stage operating principle:
 - Stage 1: High contamination loads are tackled by the cyclone-like flow and it is this that achieves the filtration performance and efficiency of a centrifugal separator.
 - Stage 2: The conical filter element guarantees the filtration rating and prevents transfer of contamination to the clean side – irrespective of fluctuations in the operating conditions and the contamination density.

MODE OF OPERATION

Filtration

- Fluid enters the housing tangentially
- The tangential inflow and the conical housing cross-section helps the fluid flow down in a spiral shape
- Particles with a high density are pressed against the tank wall by centrifugal forces and are deposited in the lower section
- Particles with a low density, which are not deposited below, are separated out by the conical wedge wire filter element with a defined filtration rating

Cleaning

- Particles that are deposited and separated at the conical wedge wire filter element collect in the lower section and are removed periodically
- Cleaning is performed by flushing with unfiltered fluid
- Continuous filtration operation as only partial flow is used for flushing

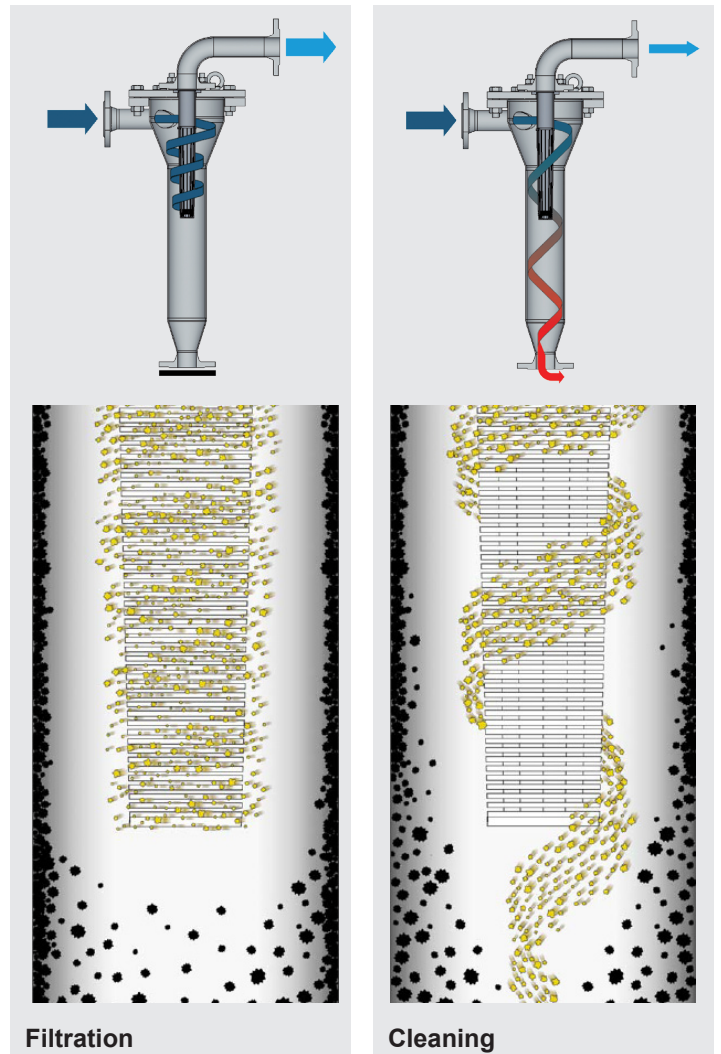

3. FILTER CALCULATION*

CHECKLIST FOR FILTER CALCULATION

STEP 1: CHECKING THE PREREQUISITES

- Application data is determined using filter questionnaires
- The flow velocity of 4 m/s at the flange inlet should not be exceeded
- Differential pressure between ATF inlet and desludging valve must not exceed 4 bar – excess values are not permitted
- Maximum permitted temperature for all AutoFilt® ATF is 90°C

STEP 2: FILTER SIZING

- Sizing based on the calculation table

STEP 3: DETERMINING THE FILTRATION RATING

- **As a basic rule:
as coarse as possible – as fine as necessary!**

STEP 4: CHECKING THE PARTICULATE LOADING

- Be aware of any variations in the contamination loads, such as those occurring in river water depending on the season

* Please contact our Head Office if you have any queries regarding filter sizing.

PRESSURE DROP CURVES

— ATF-1 (2 - 8 m³/h) - - - ATF-2 (5 - 25 m³/h) - - ATF-2.5 (15 - 60 m³/h)
 - - ATF-3 (20 - 110 m³/h) — ATF-3.5 (80 - 220 m³/h) - - - ATF-4 (100 - 400 m³/h)

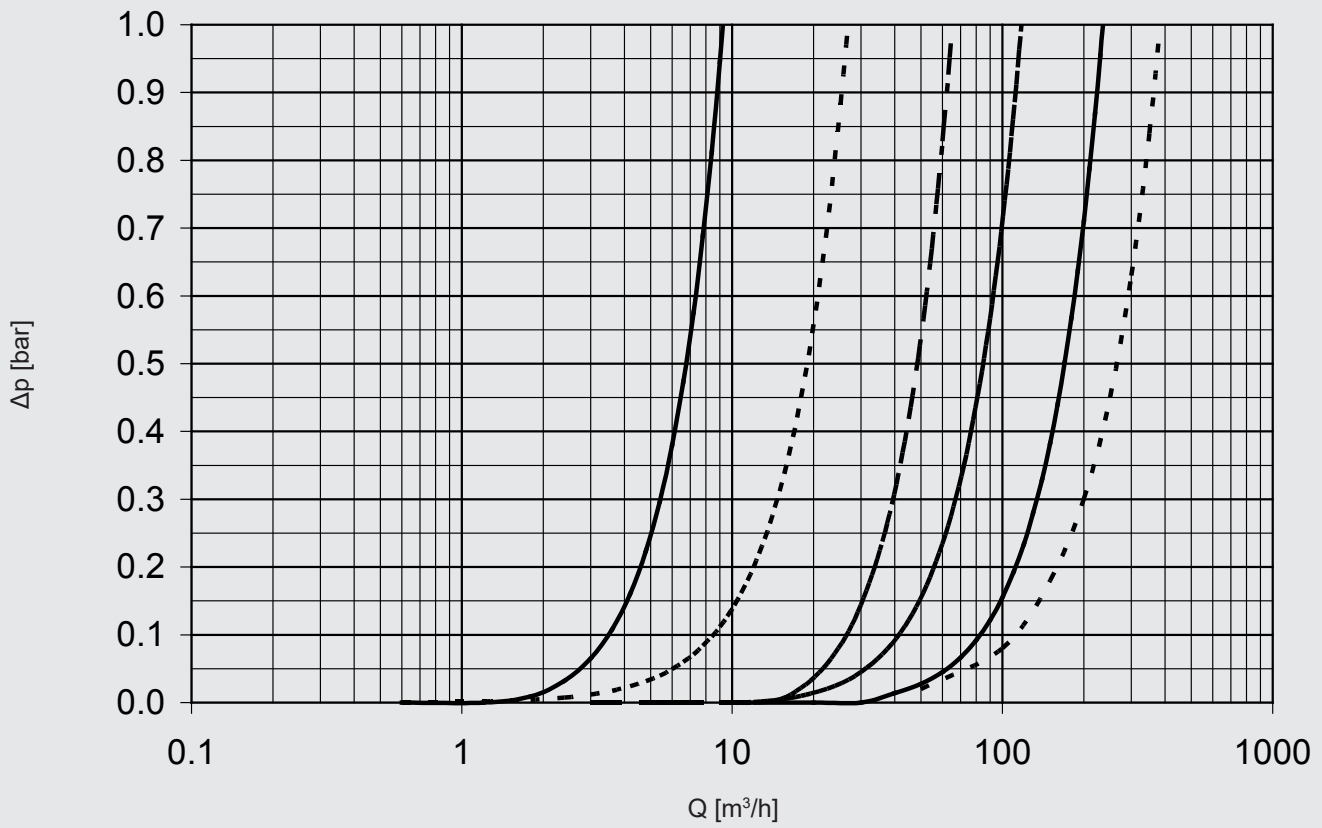

CIRCUIT DIAGRAM

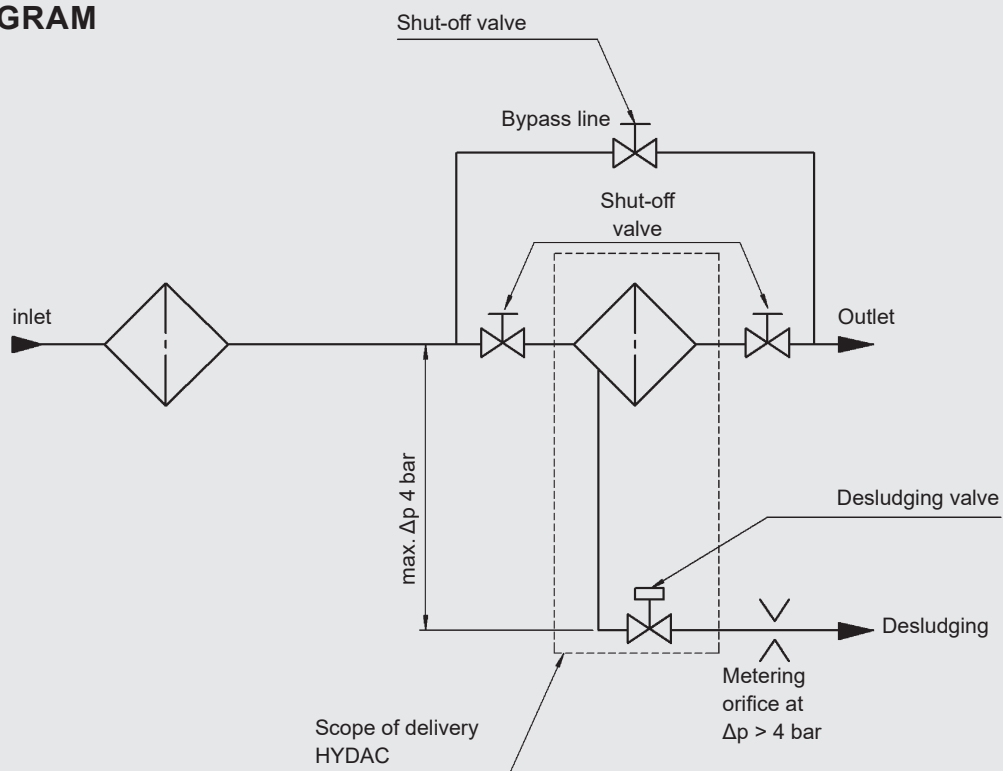

It must be ensured on the system side that no pressure difference greater than 4 bar can occur between the operating pressure of the filter and the pressure in the drain line during desludging.

This can be achieved by taking appropriate countermeasures such as using an orifice or selecting the pipe diameter in accordance with the pipe length and installations in the customer's drain line.

4. FILTER CONFIGURATION*

	Standard	Optional
Control parameters	0	<ul style="list-style-type: none"> Without drain valve Without controller
	M	Manual
	EP	Electro-pneumatic drain valve without timer function
	EPZ	Electro-pneumatic drain valve with timer function
	E	Electrical drain valve without timer function
	EZ	Electrical drain valve with timer function
Ports	<ul style="list-style-type: none"> DIN flanges Thread, ATF size 1 only 	<ul style="list-style-type: none"> ASME flanges JIS flanges NPT thread optional (ATF size 1 only)
Housing manufacture	AD 2000	<ul style="list-style-type: none"> ASME code design with or without U-stamp EN 13445
Housing materials	<ul style="list-style-type: none"> Austenitic Cr-Ni steel Carbon steel 	<ul style="list-style-type: none"> Duplex Superduplex Various qualities of stainless steel Various qualities of carbon steel
Material of filter elements	Austenitic Cr-Ni-Mo steel	<ul style="list-style-type: none"> Duplex Superduplex
External corrosion protection	2 coats of primer RAL 7040 (not required for stainless steel housing)	in acc. with customer specification
Internal corrosion protection	Inner coating 2-comp. polyurethane coating	
Accessories		<ul style="list-style-type: none"> Frame for ATF-2 / ATF-2.5 / ATF-3 Mounting clips for ATF-2 / ATF-2.5 / ATF-3 Differential pressure gauge for customer use
Documentation	Instruction manual	<ul style="list-style-type: none"> Material certificates to DIN EN 10204 Manufacturer's inspection certificate M DIN 55350-18 According to customer specification

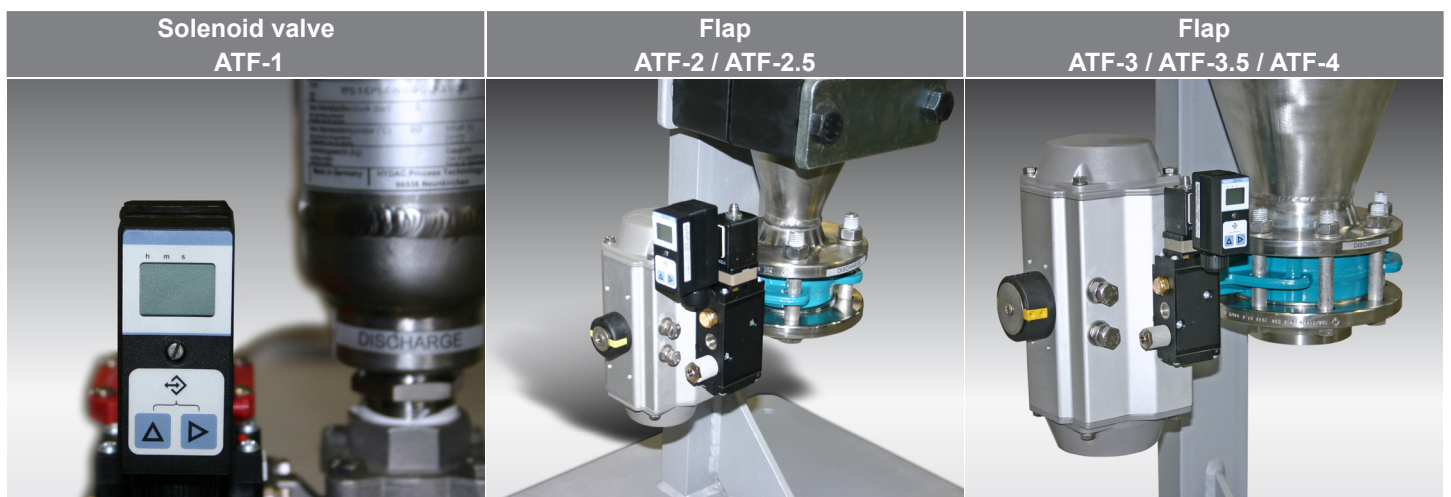

* Other versions and customer-specific special solutions after consultation with our Head Office.

5. MODEL CODE

MODEL CODE AutoFilt® TwistFlow Strainer ATF

ATF - 2 - EPZ1 - E1 - NN - 10 - 0 - 3 / UKS2 200 - 12345678

Type

AutoFilt® TwistFlow Strainer ATF

Size/connections

- 1 = inlet/outlet G 1"
- 2 = inlet/outlet DN 50
- 2.5 = inlet/outlet DN 80
- 3 = inlet/outlet DN 100
- 3.5 = inlet/outlet DN 150
- 4 = inlet/outlet DN 200

Control

- 0 = without valve
- M = manually operated drain valve
- EP = electro-pneumatically operated drain valve, without timer function
- EPZ = electro-pneumatically operated drain valve, with timer function
- E = electrically operated drain valve, without timer function
- EZ = electrically operated drain valve, with timer function

Type of voltage (EP / EPZ / E / EZ)

- 1 = control voltage 230 V AC, 50-60 HZ
- 2 = control voltage 110 V AC, 50-60 HZ
- 3 = control voltage 24 V AC, 50-60 HZ
- 4 = control voltage 24 V DC

Housing material

- N = carbon steel or ductile iron, primed externally (RAL 7040)
- E1 = stainless steel 1.4301; 1.4541 or similar (group 304 / 321) – not available for size 1
- E2 = stainless steel 1.4571 or similar (group 316)
- A = add "A" for ASME flanges
- J = add "J" for JIS flanges
- T = add "T" for NPT thread (size 1 only)
- P = add "P" for inner 2-comp. polyurethane coating

Drain valve

- 0 = no drain valve
- NN = butterfly valve GGG 40 coated, cuff NBR, stainless steel washer
- NE = butterfly valve GGG 40 coated, cuff EPDM, stainless steel washer
- NV = butterfly valve GGG 40 coated, cuff Viton, stainless steel washer
- BN = butterfly valve GGG 40 coated, cuff NBR, bronze washer
- BE = butterfly valve GGG 40 coated, cuff EPDM, bronze washer
- BV = butterfly valve GGG 40 coated, cuff Viton, bronze washer
- E = ball valve, stainless steel (size 1 only)
- M = ball valve, brass (size 1 only)

Pressure ranges

- 6 = PN 6
- 10 = PN 10
- 16 = PN 16 (for ATF-1 standard)

Equipment

- 0 = without accessories
- 1 = with base frame (only ATF-2 / ATF-2.5 / ATF-3)
- 2 = mounting clips set (only ATF-2 / ATF-2.5 / ATF-3)
- 3 = differential pressure gauge pressure chamber aluminium (only for customer use)
- 4 = differential pressure gauge pressure chamber stainless steel (only for customer use)
- 5 = differential pressure gauge pressure chamber brass (only for customer use)

Modification number

- 3 = all sizes

Element set

- UKS1 = conical wedge wire for size 1
- UKS2 = conical wedge wire for size 2
- UKS2.5 = conical wedge wire for size 2.5
- UKS3 = conical wedge wire for size 3
- UKD3.5 = conical wire mesh for size 3.5
- UKD4 = conical wire mesh for size 4
- UKL3.5 = conical perforated plate for size 3.5
- UKL4 = conical perforated plate for size 4
- SUKS1 = conical wedge wire Superflush for size 1
- SUKS2 = conical wedge wire Superflush for size 2
- SUKS2.5 = conical wedge wire Superflush for size 2.5
- SUKS3 = conical wedge wire Superflush for size 3
- SUKD3.5 = conical wire mesh Superflush for size 3.5
- SUKD4 = conical wire mesh Superflush for size 4
- SUKL3.5 = conical perforated plate Superflush for size 3.5
- SUKL4 = conical perforated plate Superflush for size 4

Filtration rating

- 200 = 200 µm (not for ATF 3.5 or ATF 4)
- 300 = 300 µm (not for ATF 3.5 or ATF 4)
- 500 = 500 µm
- 1000 = 1000 µm
- 2000 = 2000 µm
- 3000 = 3000 µm (perforated plate only)

Code number for special equipment

6. DIMENSIONS

Size AutoFilt® ATF-1

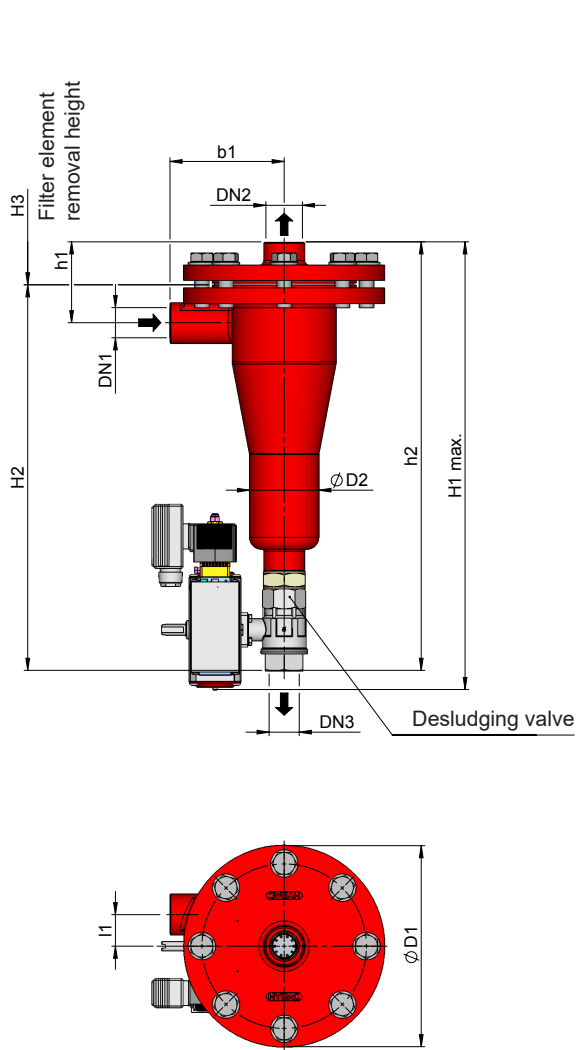

Size AutoFilt® ATF-2, ATF-2.5 to ATF-3
(Drawing shows carbon steel variant)

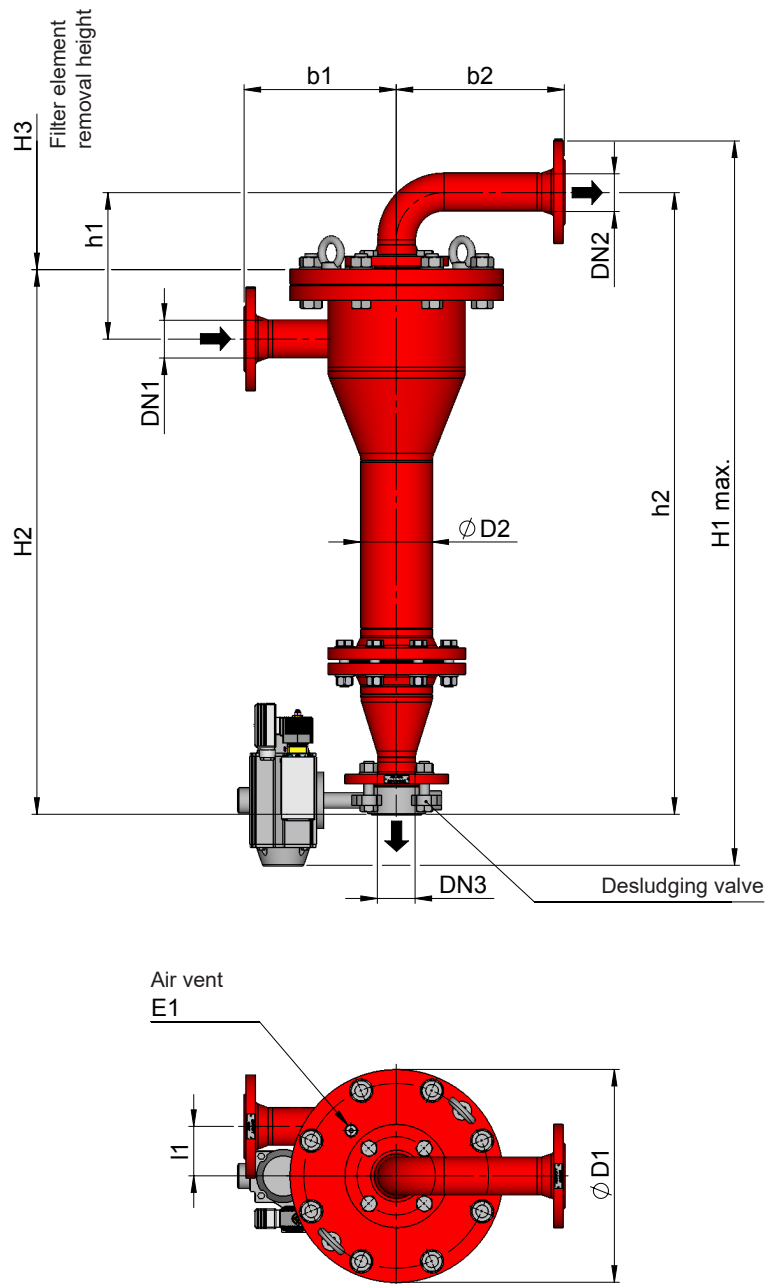

The dimensions indicated have ± 10 mm tolerances.
Subject to technical modifications.

Size	DN1	DN2	DN3	b1	b2	H1 max.	H2	H3	h1	h2	l1	D1	D2	E1
ATF-1	1"	1"	1"	125	–	490	422	350	89	470	35	220	76	–
ATF-2	50	50	50	243	269	1157	870	500	234	993	79	340	114.3	G1/4"
ATF-2.5	80	80	80	280	220	1434	1068	650	315	1235	92	395	139.7	G1/4"
ATF-3	100	100	100	322	260	1740	1292	1000	349	1498	105	445	219.1	G1/4"

6. DIMENSIONS

Size AutoFilt® ATF-3.5 to ATF-4
(Drawing shows carbon steel variant)

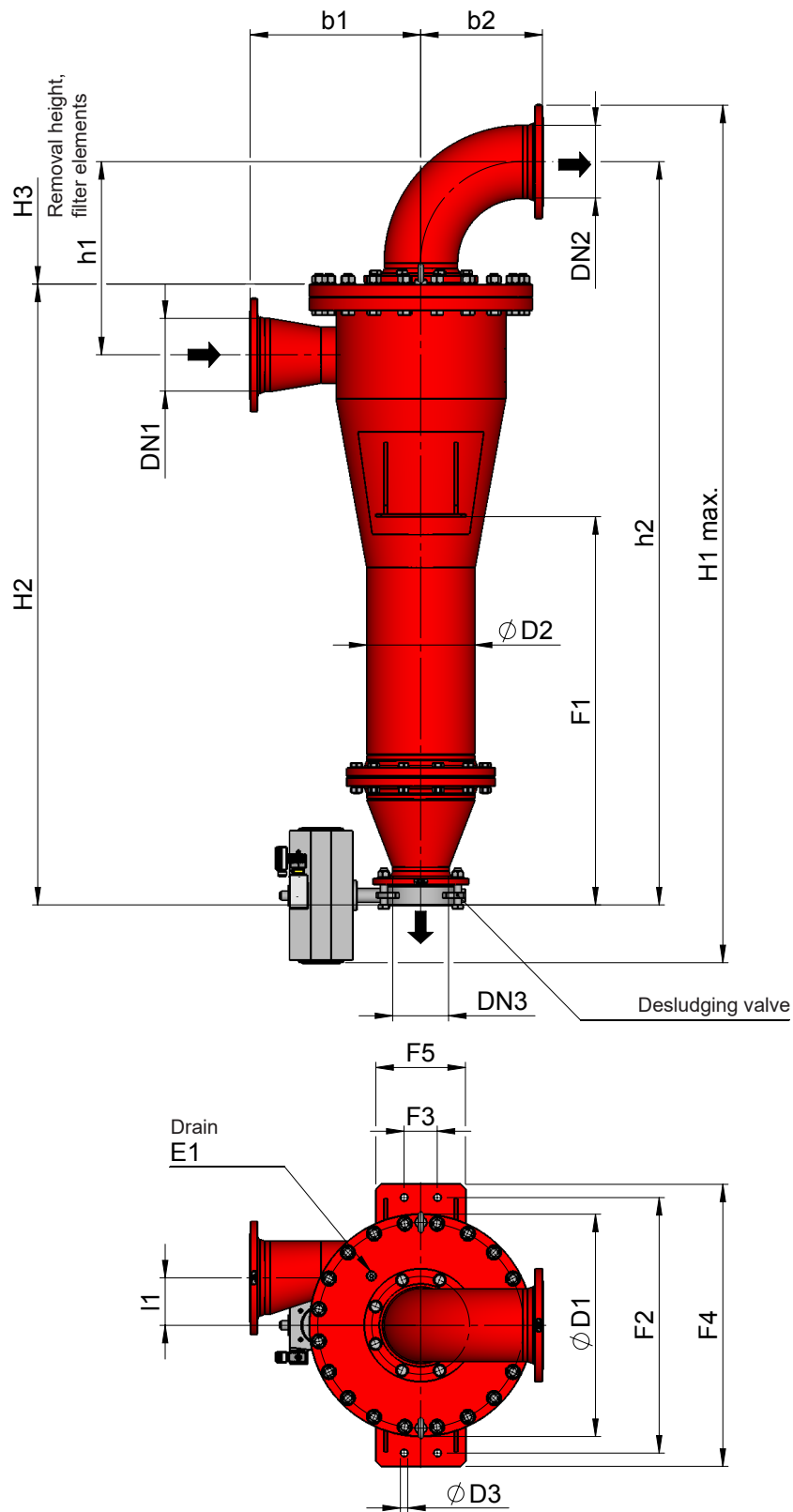

The dimensions indicated have ± 10 mm tolerances.
Subject to technical modifications.

Size	DN1	DN2	DN3	b1	b2	H1 max.	H2	H3	h1	h2	l1	D1	D2	D3	F1	F2	F3	F4	F5	E1
ATF-3.5	150	150	100	435	284	2254	1694	1300	478	1980	119	565	273	22	1127	620	80	700	130	G1/2"
ATF-4	200	200	150	514	367	2584	1871	1170	581	2240	143	670	323.9	22	1170	770	100	850	270	G1/2"

6. DIMENSIONS

Base frame for AutoFilt® ATF-2, ATF-2.5 and ATF-3 (ATF-3.5 and ATF-4 have support brackets)

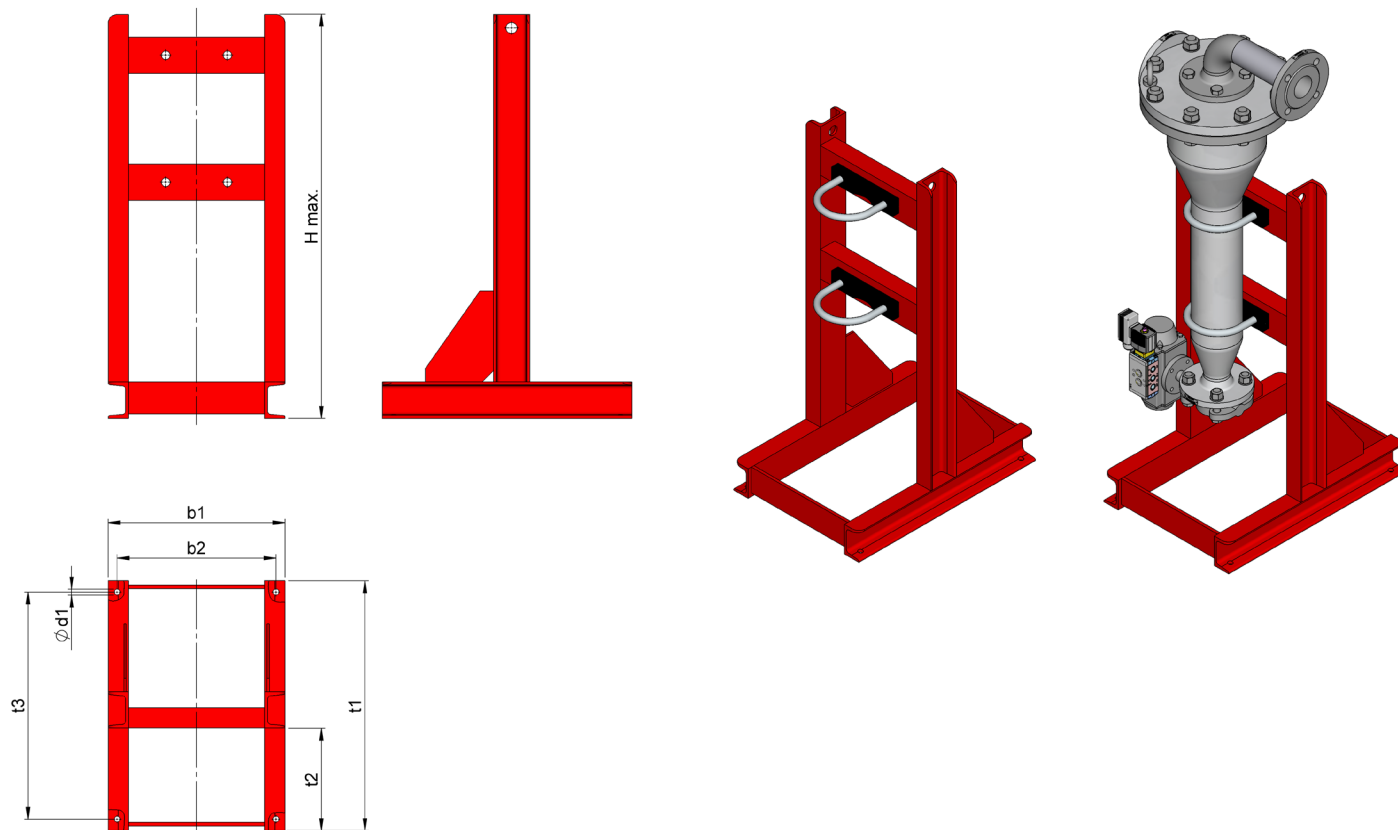

The dimensions indicated have ± 10 mm tolerances.
Subject to technical modifications.

Size	H max.	b1	b2	t1	t2	t3	d1
ATF-2	890	390	350	550	225	500	13
ATF-2.5	1180	430	380	850	320	790	17
ATF-3	1420	510	460	900	345	840	17

NOTE

The information in this brochure relates to the operating conditions and applications described.

For applications and/or operating conditions not described please contact the relevant technical department.

Subject to technical modifications.

HYDAC Process Technology GmbH
Am Wrangelflöz 1
D-66538 Neunkirchen
Tel.: +49 (0)6897 - 509-1241
Fax: +49 (0)6897 - 509-1278
Internet: www.hydac.com
E-mail: prozess-technik@hydac.com