

Automated Laboratory Particle Counter

ALPC 9000 Series

Description

The Automated Laboratory Particle Counter ALPC 9000 is a fully automatic laboratory particle measurement system for hydraulic and lubrication oils.

Very short measuring times permit analysis of up to 500 samples per day.

Different versions of the ALPC offer either automatic sample feed by means of 5-axis robotic arm (batch processing) or manual sample feed of individual sample bottles.

Applications

- Laboratories

Advantages

- Automatic and monitored processing of measurement and rinsing cycles.
- Rapid sample analysis due to very short cycle times for measurement and rinsing.
- Excellent repeatability of the measurement results by means of replicated testing.
- Only small sample quantities are required (≈ 50 ml).
- User-friendly operation and graphical evaluation of the results through the use of ALPC Desk software.
- Calibrated to ISO11171 and ISO4402: consequently analysis according to NAS 1638 is also possible.
- "All-in-one" system including PC, keyboard and monitor. Robotic arm available as an option.
- Bar code scanner compatible.

Technical specifications

Self diagnostics	Continuous display and error indication on the PC
Measurement range (calibrated)	ISO 0/0/0 ... 23/21/18
Calibration	Particle size
ISO 4402 and ISO 11171	5, 10, 15, 20, 25, 50, 75, 100 μm 4, 6, 10, 14, 18, 21, 38, 50 $\mu\text{m}_{(c)}$
Measured volume per sample bottle (2 .. 5 individual measurements)	10 ... 25 ml (min. sample bottle volume: 50 ml)
Sensor flow rate	30 ml/min
Measurement cycle time (measuring and rinsing; typically)	≈ 75 seconds (excluding sample feed)
Permitted fluids	Hydraulic and lubrication fluids based on mineral oil
Permitted rinsing fluid	See Page 2 "Services required on site"
Rinsing fluid consumption	≈ 50 ml / sample bottle
Permitted viscosity range	1 ... 320 mm^2 / s
Permitted fluid temperature range	0 ... 50 °C, 32 ... 122 °F
Compressed air supply (provided by customer)	6.5 ... 8 bar, 100 l/min
Power consumption	2000 W max. (230 V, max. 8.7 A)
Permitted ambient temperature range	10 ... 45 °C, 50 ... 113 °F Depending on rinsing fluid. Higher temperatures possible on request.
Permitted storage temperature range	0 ... 70 °C, 32 ... 158 °F
Permitted ambient humidity	Max. 90%, non-condensing
Weight:	ALPC 9000 -1: ≈ 100 kg ALPC 9000 -2: ≈ 160 kg

Equipment

	ALPC 9000-1	ALPC 9000-2
Automatic measurement	✓	✓
Automatic rinsing	✓	✓
PC/Monitor/Keyboard	✓	✓
Individual sample bottle feed	✓	✓
Multiple sample feed of up to 50 samples on pallet		✓
Sample bottle shaker		✓
5-axis robotic arm		✓
ALPC Desk software	✓	✓
Degassing function incorporated into robotic arm		✓
Prepared for upgrade to ALPC 9000-2	✓	
Bar code scanner compatible	✓	✓

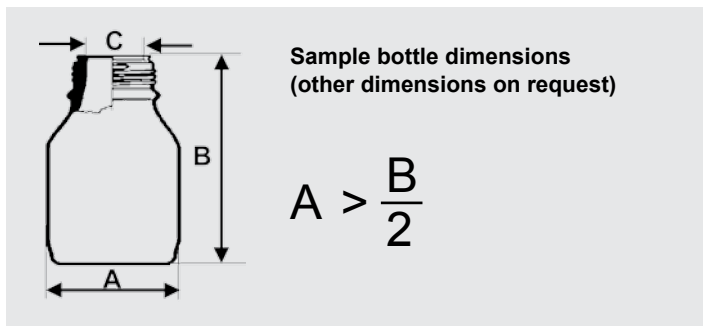

A	B	C	ALPC 9000-1	ALPC 9000-2
< 52 mm	60 ... 90 mm	25 ... 35 mm		✓
< 75 mm	60 ... 90 mm	25 ... 35 mm	✓	

Services required on site *

- Supply voltage
- Dry, clean compressed air (see Page 1)
- Rinsing fluid: Mineral oil based fluids with flash point $\geq 56^\circ\text{C}$ (preferably kerosene). Cleanliness must be significantly better (by a factor of 2-3) than the expected sample cleanliness
- Reservoir for rinsing and waste fluids (min. 2 x 10 l)

* not supplied

Dimensions (all dimensions approximate in mm)

ALPC 9000-1

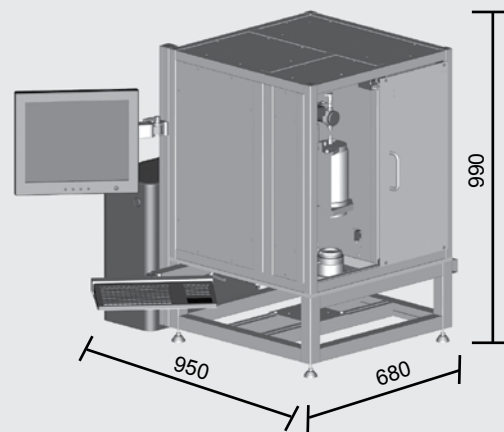

ALPC 9000-2

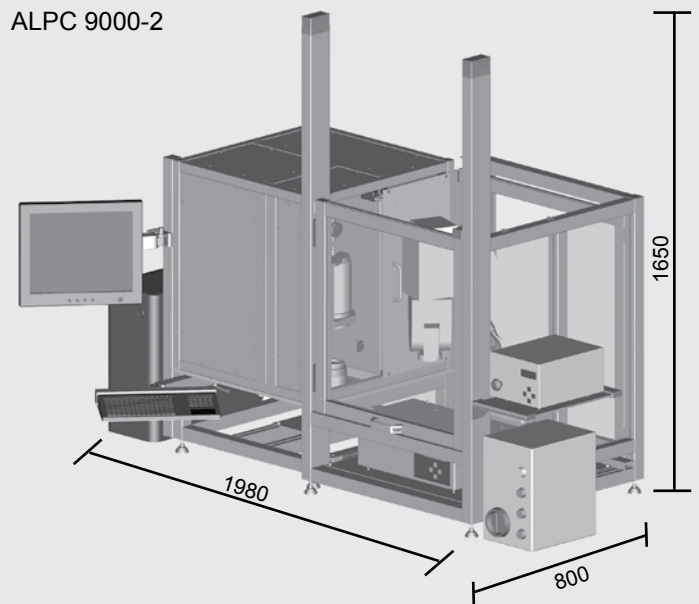

PC Software ALPC Desk

User-friendly processing and display of the measured data using ALPC Desk software

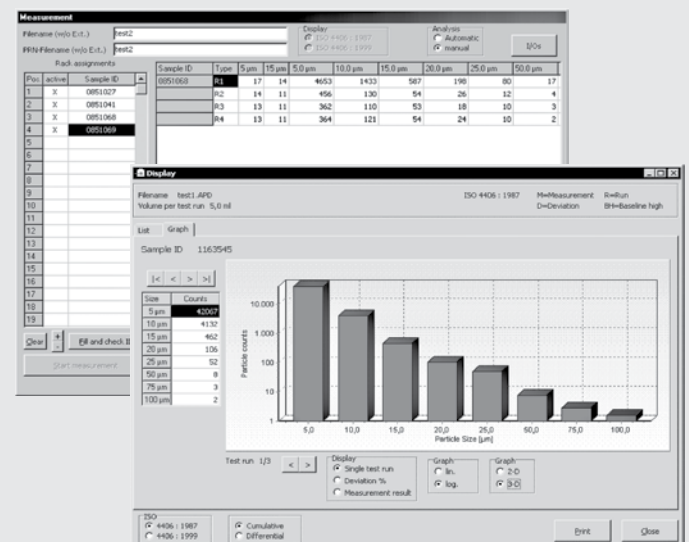

Dimensions (all dimensions approximate in mm)

ALPC

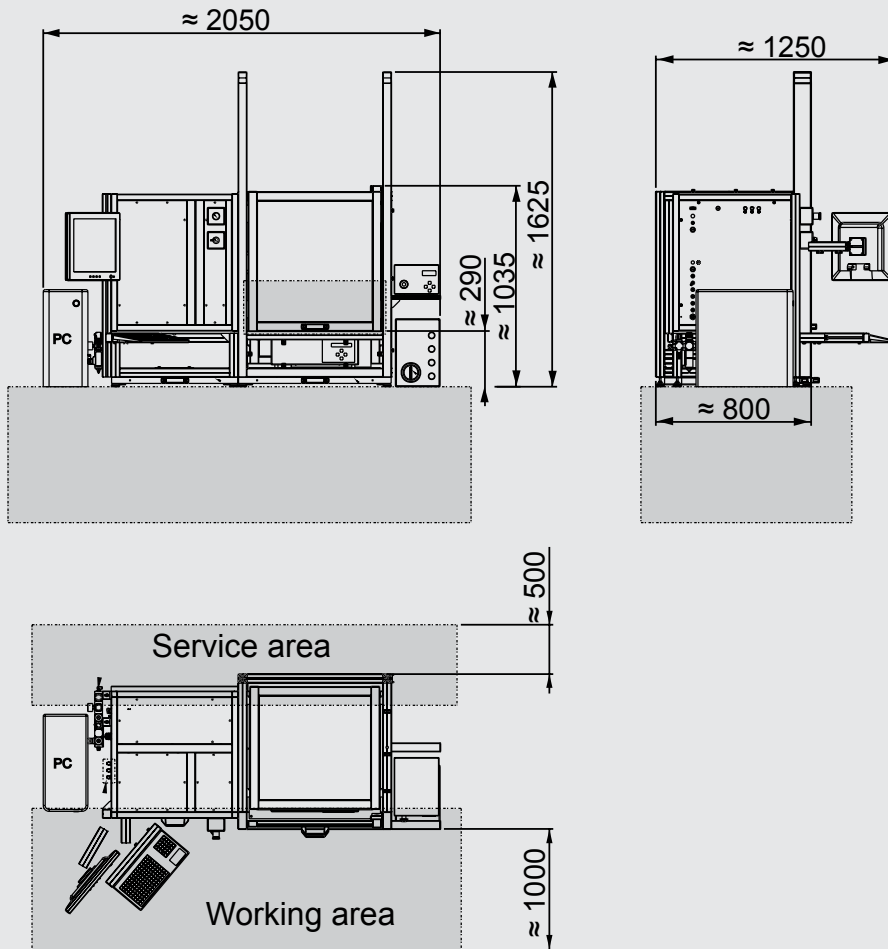

Items supplied

- ALPC 9000-1 / 9000-2
- ALPC 9000-2 only: sample bottle shaker, robotic arm with transparent Makrolon® safety enclosure
- PC, 19" TFT monitor, keyboard with touchpad
- Software ALPC Desk installed on PC and on CD-ROM
- Calibration certificate
- Operating manual
- Service documentation installed on PC and on CD-ROM

Model code

ALPC 9000 1 M W7 DE

Type _____
ALPC = Automatic Laboratory Particle Counter

Series _____
9000

Sample feed _____
1= manual
2= automatic

Supply voltage _____
M = 230 VAC, 50 / 60 Hz
Other voltage on request

PC operating system _____
W7 = Windows 7 (32-Bit)

Keyboard _____
BE = Belgium
CH = Switzerland
DE = Germany
DK = Denmark
ES = Spain
FR = France
GB = England
IT = Italy
NO = Norway
PO = Portugal
SF = Sweden, Finland
US = USA

NOTE

The information in this brochure relates to the operating conditions and applications described.

For applications or operating conditions not described, please contact the relevant technical department.

Subject to technical modifications.

HYDAC FILTER SYSTEMS GMBH
Industriegebiet
D-66280 Sulzbach / Saar
Tel.: +49 (0) 6897/509-01
Fax: +49 (0) 6897/509-846
Internet: www.hydac.com
E-Mail: filtersystems@hydac.com