



Process Multi-Rheo Filter, Duplex Change-Over PMRFD

PMRFD-2



PMRFD-3



PMRFD-5

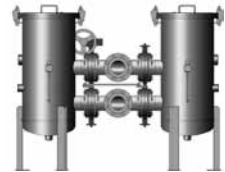

1. TECHNICAL SPECIFICATIONS

1.1 GENERAL

The filter series PMRFD (for single filters see PMRF) Process Multi-Rheo Change-over Filter completes the HYDAC Process Technology inline filter series. These filters use HYDAC FlexMicron filter elements. The elements feature outstanding contamination retention capacities. The filter housings are available in 7 different sizes and lengths and therefore a suitable filter can be found for every process. By using clogging indicators which monitor the differential pressure, the condition of the filter can be determined at any time.

Typical areas of application for this filter series are:

- Process water treatment
- Filtration of cooling lubricants and washing fluids
- Pure and ultrapure water production
- Boiler feed water
- Extending the service life of circulating fluids
- Protection filtration for UV and membrane systems

1.2 HOUSING

The filter housings in the PMRFD series are designed in accordance with international regulations. They are available in carbon steel or stainless steel and in various lengths.

1.3 FILTER ELEMENTS

1.3.1 FlexMicron E (Economy)

The filter elements in the FlexMicron E (Economy) product line are depth filter elements produced using melt-blown technology. They are used particularly in applications where an average level of fluid cleanliness and material purity is required and they provide a cost-effective solution.

Available lengths 10", 20", 30", 40" with a filtration rate of 95 %.

1.3.2 FlexMicron S (Standard)

The filter elements in the FlexMicron S (Standard) product line are SpunSpray depth filter elements produced using melt-blown technology. They are used particularly in applications where a high level of fluid cleanliness and

material purity is required.

Available lengths 10", 20", 30", 40" with a filtration rate of 99.8 %.

1.3.3 FlexMicron P (Premium)

The filter elements in the FlexMicron P (Premium) product line are heavy-duty pleated elements, produced using melt-blown or top-quality glass fibre technology. They are used particularly in applications requiring high levels of cleanliness. Available lengths 10", 20", 30", 40" with a filtration rate of up to 99.99 %.



2. FILTER SPECIFICATIONS

2.1 SUMMARY OF TECHNICAL SPECIFICATIONS OF THE FILTER HOUSING (STANDARD CONFIGURATION)

Size	Length [inches]				Connection		Materials			Pressure range					Temperature [°C]	Weight [kg]	Volume [l]	
	10	20	30	40	SAE	Pipe thread G	DIN DN	Stainless steel ¹⁾	Carbon steel with int. corrosion protection	Carbon steel without int. corrosion protection	PN6	PN10	PN16	PN25				PN40
1	●	●	●	●		1"		●				●			●	-10 to 90	14	2x 8.4
2	●	●	●	●		2"	2", 1.5"	50	●			●	●				85	2x 38
3	●	●	●	●		2"	2", 1.5"	50	●			●	●				100	2x 65
4 ³⁾				●			50/ 80/ 100		●	●	●	●	●	●			290	2x 120
5 ³⁾				●			80/ 100/ 150		●	●	●	●	●	●			470	2x 180
6 ³⁾				●			100/ 150/ 200		●	●	●	●	●	●			730	2x 240
7 ³⁾				●			150/ 200/ 250		●	●	●	●	●	●			890	2x 465

¹⁾ Size 1 in stainless steel 1.4571, sizes 2 to 7 in stainless steel 1.4301

²⁾ based on length of 40 inches

³⁾ includes cover lifting device

2.2 FURTHER SPECIFICATIONS OF THE FILTER HOUSING

2.2.1 Seal materials

- NBR
- FPM (Viton)
- EPDM

2.2.2 Corrosion protection, external

- 2 layer primer (not required for stainless steel filters)

2.2.3 Corrosion protection, internal

- 2K epoxy coating (not required for stainless steel filters or for type NU)

2.2.4 Documentation

- Operating and maintenance instructions

2.3 OPTIONAL VERSIONS OF FILTER HOUSING

There are a range of optional versions available for the PRMFD. For technical details and prices, please contact our Technical Sales Department at Head Office.

2.3.1 Housing manufacture

- ASME Code Design (with or without U-Stamp)

2.3.2 Flange connections

- ANSI
- JIS

2.3.3 Housing materials

- Various qualities of stainless steel
- Various qualities of carbon steel

2.3.4 Seal materials

- Various seal materials on request, depending on the resistance to the fluid.

2.3.5 Corrosion protection and external finishes

- RAL colours acc. customer requirements
- Various multi layer coatings

2.3.6 Differential pressure monitoring

- Visual
- Electrical
- Visual electrical
- Differential pressure gauge with 2 microswitches

2.3.7 Documentation

- Manufacturer's test certificates
 - Material certificates (3.1 according to DIN EN 10204)
 - 3rd parties (TÜV, ABS, Lloyds, etc.)
 - Welding procedure specifications (WPS) / Procedure Qualification Record (PQR)
 - Inspection plan and many other documents available on request
- Further optional models on request.

2.4 SUMMARY OF TECHNICAL SPECIFICATIONS OF FILTER ELEMENTS

2.4.1 FlexMicron E (Economy)

Size	No. of filter elements	Filter element type	Filter materials and filtration ratings [μm]	
			Polypropylene	Polyamide
1	1	FlexMicron E	Not available	
2	3 or 5	FlexMicron E	1, 3, 5, 10, 20, 30, 40, 50, 70, 90	
3	7 or 11	FlexMicron E		
4	17	FlexMicron E		
5	22	FlexMicron E		
6	36	FlexMicron E		
7	52	FlexMicron E		

2.4.2 FlexMicron S (Standard)

Size	No. of filter elements	Filter element type	Filter materials and filtration ratings [μm]	
			Polypropylene	Polyamide
1	1	FlexMicron S	Not available	
2	3 or 5	FlexMicron S	1, 3, 5, 10, 20, 30, 40, 50, 70, 90	
3	7 or 11	FlexMicron S		
4	17	FlexMicron S		
5	22	FlexMicron S		
6	36	FlexMicron S		
7	52	FlexMicron S		

2.4.2 FlexMicron P (Premium)

Size	No. of filter elements	Filter element type	Filter materials and filtration ratings [μm]	
			Polyester	Glass fibre
1	1	FlexMicron P	Not available	
2	3 or 5	FlexMicron P	1, 3, 5, 10, 20, 30, 40, 50, 70, 90	
3	7 or 11	FlexMicron P		
4	17	FlexMicron P		
5	22	FlexMicron P		
6	36	FlexMicron P		
7	52	FlexMicron P		

2.4.4 Permissible differential pressure

The maximum permissible differential pressure of the elements is dependent on the temperature in the application. Please refer to the table below:

Temperature	Filter material		
	PES	PP	PA
-10 ... + 30 °C	8 bar	4 bar	7 bar
-10 ... + 60 °C	6.5 bar	2 bar	5.5 bar
-10 ... +100 °C	5 bar	–	3.5 bar

2.5 CIRCUIT DIAGRAM

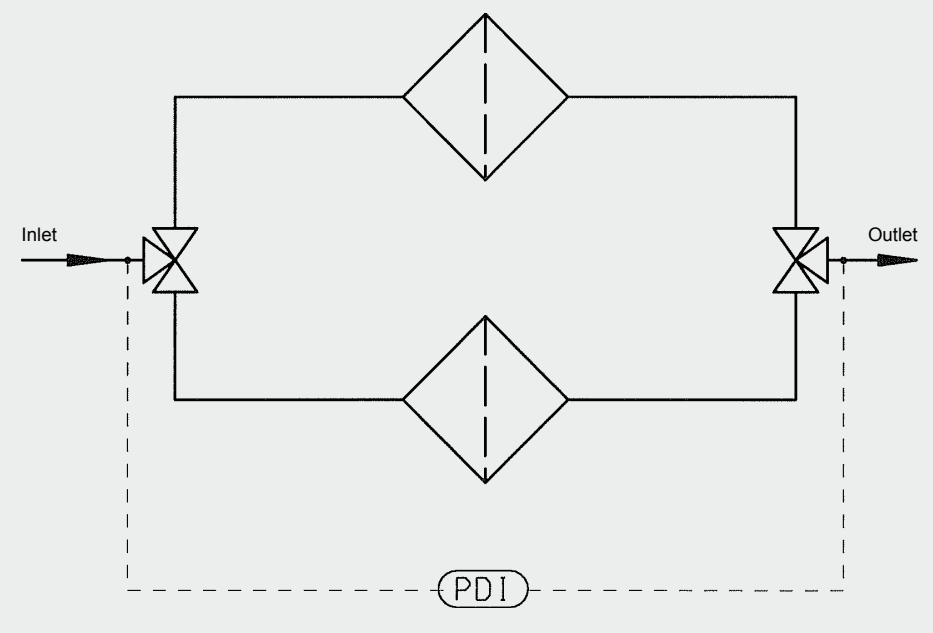

3. MODEL CODE PMRFD

PMRFD - 4 - E / 17 - Q - 40 - 10 - F - 1 - X

Type

PMRFD = Process Multi Rheo Change-Over Filter

Size

- 1 = approx. 76 mm housing diameter
- 2 = approx. 223 mm housing diameter
- 3 = approx. 274 mm housing diameter
- 4 = approx. 355 mm housing diameter
- 5 = approx. 406 mm housing diameter
- 6 = approx. 508 mm housing diameter
- 7 = approx. 610 mm housing diameter

Housing material

	for size						
	1	2	3	4	5	6	7
E = stainless steel*							
NU = carbon steel uncoated*				4	5	6	7
NM = carbon steel with internal 2K epoxy coating*				4	5	6	7

*For quality, see technical specifications

Bold = standard

Number of elements

	for size						
	1	2	3	4	5	6	7
1 = 1 filter element	1						
3 = 3 filter elements		2					
5 = 5 filter elements		2					
7 = 7 filter elements			3				
11 = 11 filter elements			3				
17 = 17 filter elements				4			
22 = 22 filter elements					5		
36 = 36 filter elements						6	
52 = 52 filter elements							7

Connection type

	for size						
	1	2	3	4	5	6	7
D = G 1"							
F = G1/ 1/2"		2	3				
G = G 2"		2	3				
L = SAE DN50		2	3				
J = DIN DN 50		2	3				
Q = DIN DN 80				4			
R = DIN DN 100					5		
V = DIN DN 150						6	
W = DIN DN 200							7

Element size

	for size						
	1	2	3	4	5	6	7
10 = 10"							
20 = 20"							
30 = 30"							
40 = 40"				4	5	6	7

Pressure range

	for size						
	1	2	3	4	5	6	7
6 = 6 bar			3				
10 = 10 bar	1	2	3	4	5	6	7
16 = 16 bar				4	5	6	7
25 = 25 bar				4	5	6	7
40 = 40 bar	1			4	5	6	7

Bold = standard

Seal material

- N = NBR
- F = FPM (Viton)
- E = EPDM

Clogging indicator

- 0 = without
- 1 = with visual indicator (PVD 2B.1)
- 2 = with visual-electrical indicator (PVD 2D.0/-L..)
- 3 = V01
- 4 = differential pressure gauge AL (measuring range 4 bar)
- 5 = differential pressure gauge stainless steel (measuring range 4 bar)
- 6 = with electrical indicator (PVD 2C.0)

See Brochure no.:D7.706.1... Clogging Indicators for Process Filters

Modification number

- X = the latest version is always supplied

3.1 MODEL CODE FLEXMICRON E (ECONOMY) ELEMENTS

N - 40 - FM-E - 005 - PP - 1 - F

Element length

10 = 10" 30 = 30"
20 = 20" 40 = 40"

Element type

FM-E= FlexMicron E (Economy)

Filtration rating

001 = 1 µm 010 = 10 µm 040 = 40 µm 090 = 90 µm
003 = 3 µm 020 = 20 µm 050 = 50 µm
005 = 5 µm 030 = 30 µm 070 = 70 µm

Material of filter element

PP = polypropylene

End cap type

0 = compression ring (DOE), no cap or seal (Ø 64 mm)
1 = plug-in adapter (1x 222 O-ring), flat end cap (Ø 64 mm)
2 = plug-in adapter (2x 222 O-ring), flat end cap (Ø 64 mm)
10 = gasket (DOE) (Ø 64 mm)
13 = plug-in adapter (2x 222 O-ring), locating spigot (Ø 64 mm)
14 = bayonet (2x 226 O-ring), locating spigot (Ø 64 mm)
others on request

Seal material

F = FPM
N = NBR
E = EPDM
Z = no seal (only for end cap form 0)
Other types of element on request

3.2 MODEL CODE FLEXMICRON S (STANDARD) ELEMENTS

N - 40 - FM-S - 005 - PP - 1 - F

Element length

10 = 10" 30 = 30"
20 = 20" 40 = 40"

Element type

FM-S= FlexMicron S (Standard)

Filtration rating

001 = 1 µm 010 = 10 µm 040 = 40 µm 090 = 90 µm
003 = 3 µm 020 = 20 µm 050 = 50 µm
005 = 5 µm 030 = 30 µm 070 = 70 µm

Material of filter element

PP = polypropylene
PA = polyamide

End cap type

0 = compression ring (DOE), no cap or seal (Ø 64 mm)
1 = plug-in adapter (1x 222 O-ring), flat end cap (Ø 64 mm)
2 = plug-in adapter (2x 222 O-ring), flat end cap (Ø 64 mm)
10 = gasket (DOE) (Ø 64 mm)
13 = plug-in adapter (2x 222 O-ring), locating spigot (Ø 64 mm)
14 = bayonet (2x 226 O-ring), locating spigot (Ø 64 mm)
others on request

Seal material

F = FPM
N = NBR
E = EPDM
Z = no seal (only for end cap form 0)
Other types of element on request

3.1 MODEL CODE FLEXMICRON P (PREMIUM) ELEMENTS

N - 40 - FM-P - 005 - PES - 1 - F

Element length

10 = 10" 30 = 30"
20 = 20" 40 = 40"

Element type

FM-P= FlexMicron P (Premium)

Filtration rating

001 = 1 µm 010 = 10 µm 020 = 20 µm 040 = 40 µm
003 = 3 µm 005 = 5 µm 030 = 30 µm

Material of filter element

PP = polypropylene
GF = glass fibre

End cap type

0 = compression ring (DOE), no cap or seal (Ø 64 mm)
1 = plug-in adapter (1x 222 O-ring), flat end cap (Ø 64 mm)
2 = plug-in adapter (2x 222 O-ring), flat end cap (Ø 64 mm)
10 = gasket (DOE) (Ø 64 mm)
13 = plug-in adapter (2x 222 O-ring), locating spigot (Ø 64 mm)
14 = bayonet (2x 226 O-ring), locating spigot (Ø 64 mm)
others on request

Seal material

F = FPM
N = NBR
E = EPDM
Other types of element on request

4. FILTER CALCULATION / SIZING

4.1 PRESSURE DROP CURVES HOUSING

The pressure drop curves apply to water and other fluids up to a viscosity of 15 mm²/s.

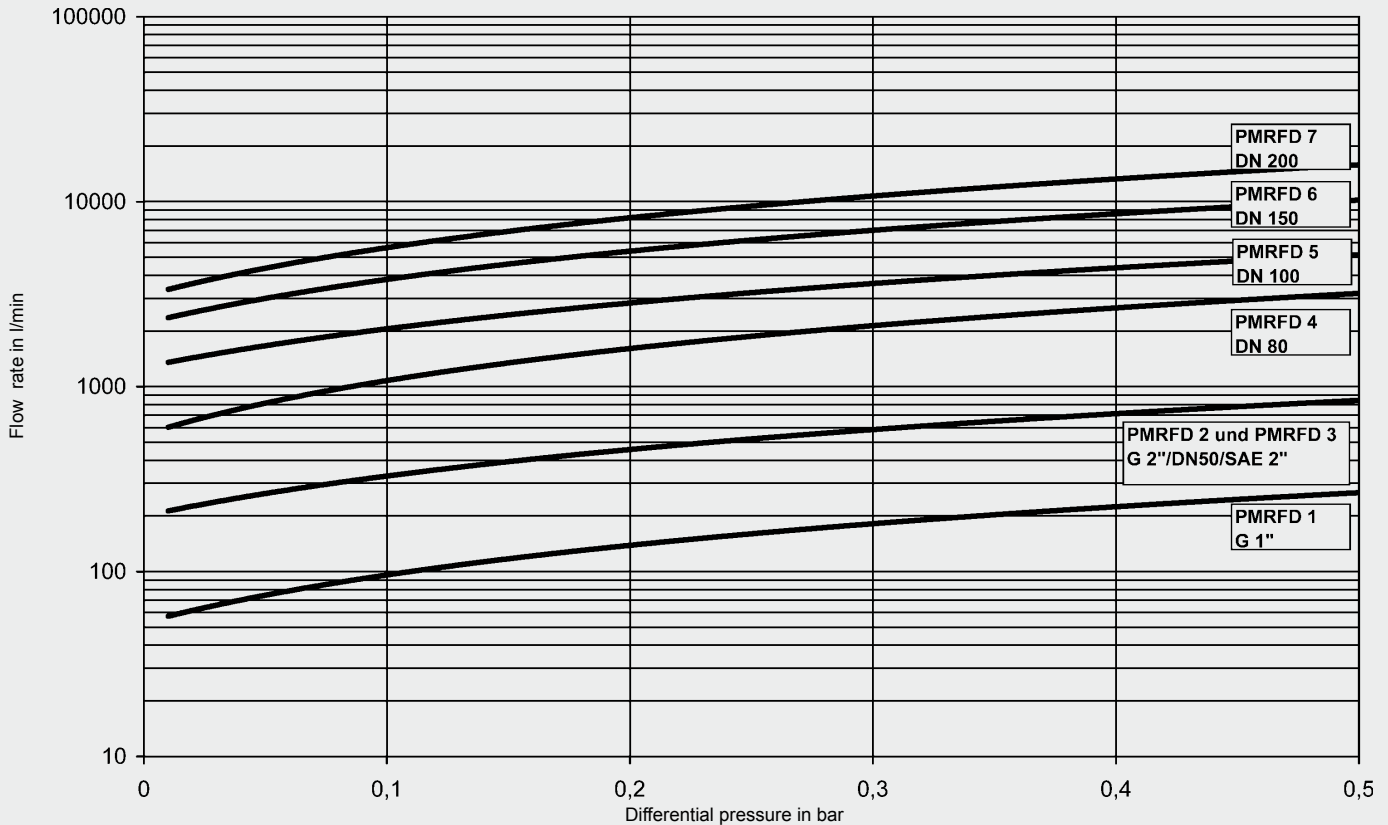

The total pressure drop of the filter at a certain flow rate is the sum of the housing Δp and the element Δp .

The housing pressure drop can be determined using the following pressure drop curves. The pressure drop of the elements is calculated using the R factors.

In order to be able to size the filter correctly, the following design data should be available:

- Flow rate
- Type of medium
- Materials/resistance
- Viscosity
- Required filtration rating
- Particulate loading in the fluid
- Type of contamination
- Operating pressure
- Operating temperature
- Integration of the PMRFD into the whole system

A further factor in the calculation is the flow velocity through the flange inlet. It should not exceed 4 m/s.

4.2 PRESSURE DROP CALCULATION FOR ELEMENTS

The pressure drop for elements in clean condition is calculated as follows:

$$\Delta p [\text{bar}] = \frac{R \times V [\text{mm}^2/\text{s}] \times Q [\text{l}/\text{min}]}{n \times l [\text{inch}] \times 1000}$$

R = R factor
 V = viscosity [mm²/s]
 Q = flow rate [l/min]
 n = no. of elements
 L = element length [inch]

FlexMicron E (Economy) R (resistance) factors

R factors	Water-based fluids	
	PA	PP
Filtration rating [μm]	1	37.0
	3	29.0
	5	20.0
	10	11.0
	20	8.0
	30	6.8
	40	5.4
	50	4.2
	70	3.1

FlexMicron S (Standard) R (resistance) factors

R factors	Water-based fluids		
	PA	PP	
Filtration rating [μm]	1	274	321
	3	116	186
	5	42	132
	10	15	99
	20	11	54
	30	6	16
	40	3.8	12
	50	1.9	10
	70	1.1	8
	90	0.6	6

FlexMicron P (Premium) R (resistance) factors

R factors	Water-based fluids			
	PES*	PES*	GF**	
Filtration rating [μm]	1	32	10.4	5.4
	3	24	7.5	-
	5	18	4.4	4.3
	10	17	1.8	3.2
	20	15	1.8	-
	30	14	0.9	-
	40	14	0.9	-

*β > 5000

**β > 20000

5. DIMENSIONS

5.1 DIMENSIONS OF FILTER HOUSING

The dimensions given below are based on standard pressure ranges in combination with stainless steel or uncoated carbon steel housings. For carbon steel with internal coating, the filter housing is divided into an upper and lower section. This increases the overall height of the housing.

PMRFD 1

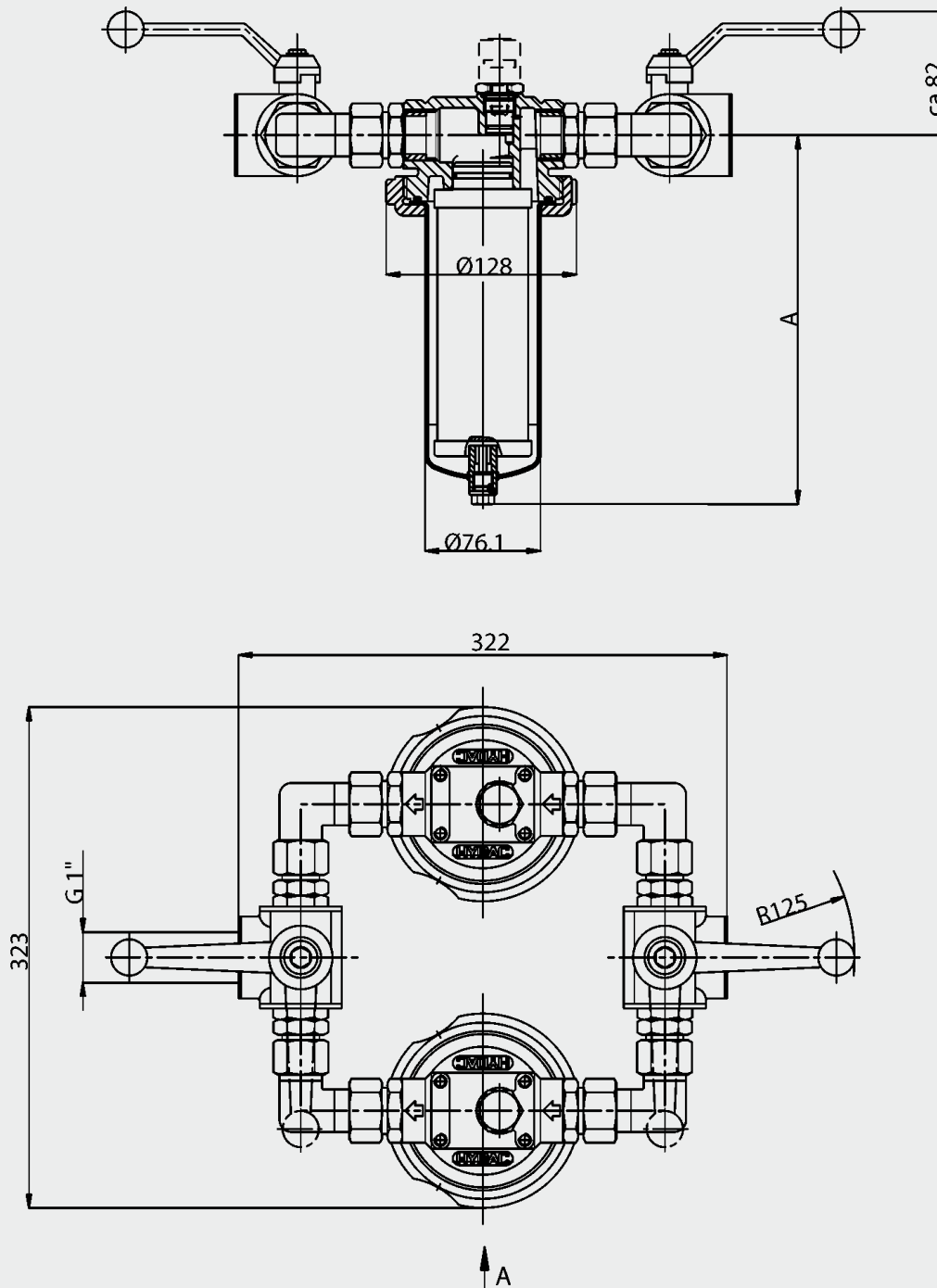

Length	A	Volume [l]
10"	332.5	2 x 1.1
20"	586.5	2 x 2.1
30"	816	2 x 3
40"	1094.5	2 x 4

- The filter must not be used as a pipe support.
- The dimensions quoted have ± 5 mm tolerances for sizes up to 3.
- The dimensions quoted have ± 10 mm tolerances for sizes 4 upwards.

PMRFD 2

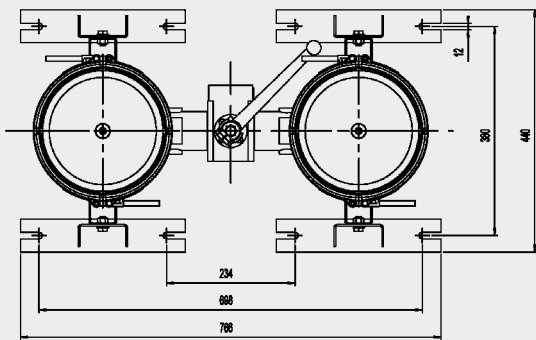
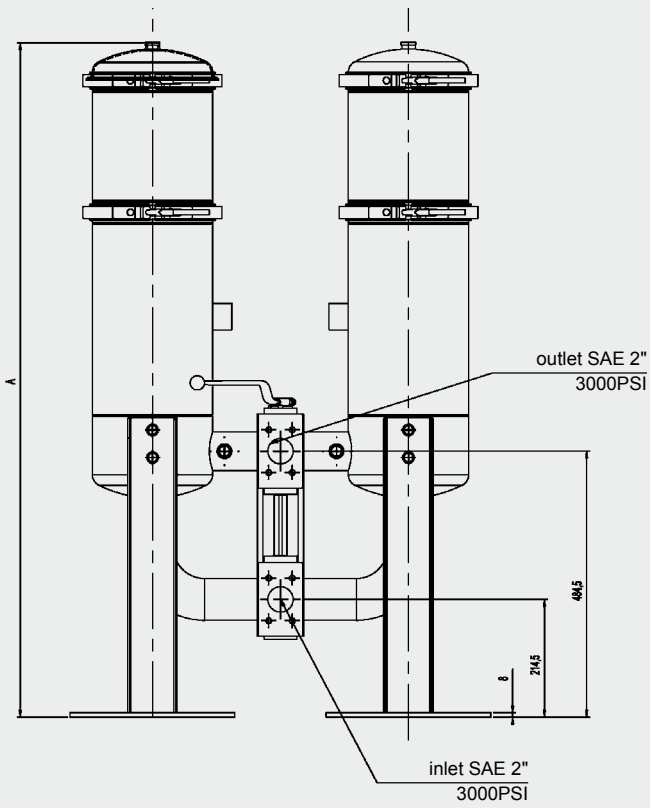

PMRFD 3

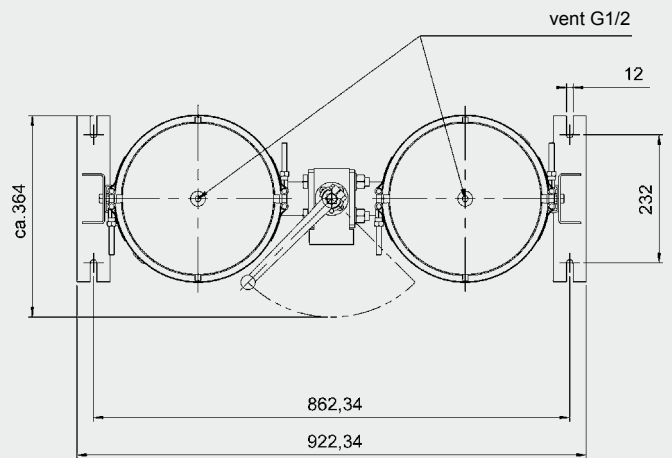
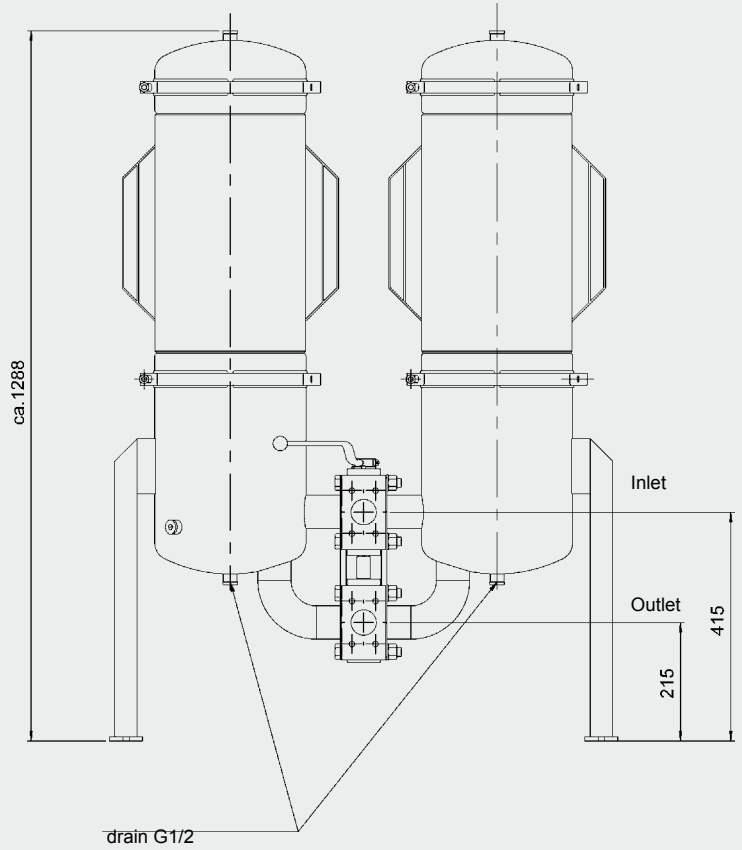

Length	A	Volume [l]
10"	975	2 x 17
20"	1215	2 x 26
30"	1433	2 x 35
40"	1682	2 x 45

Length	A	Volume [l]
10"	798	2 x 20
20"	1066	2 x 40
30"	1323	2 x 50
40"	1578	2 x 65

- The filter must not be used as a pipe support.
- The dimensions quoted have ± 5 mm tolerances for sizes up to 3.
- The dimensions quoted have ± 10 mm tolerances for sizes 4 upwards.

PMRFD 4

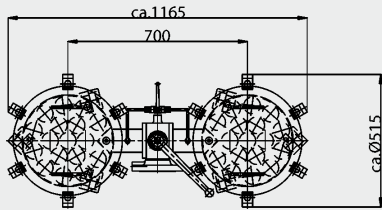
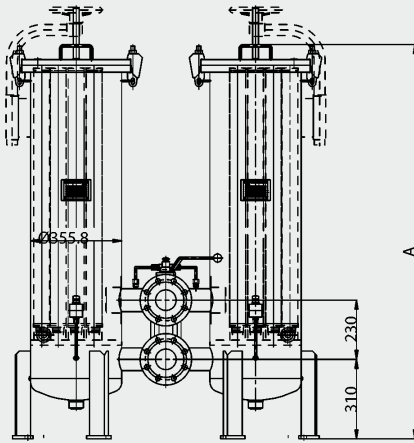

PMRFD 5

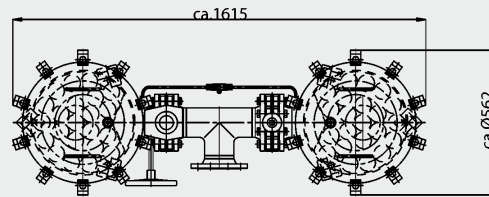
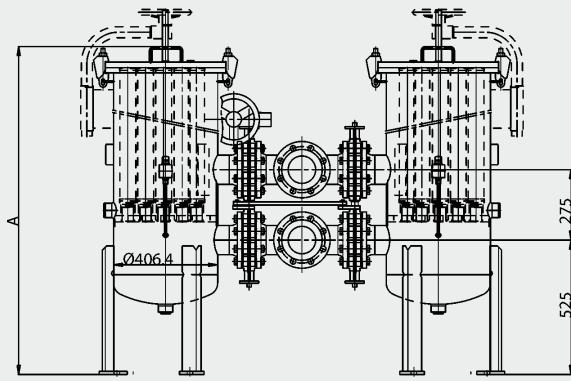

PMRFD 6

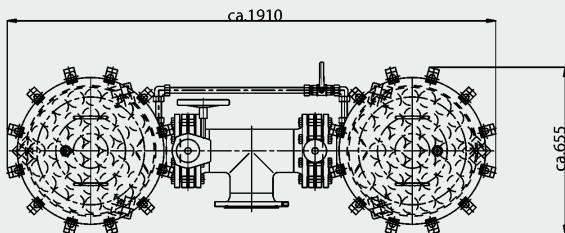
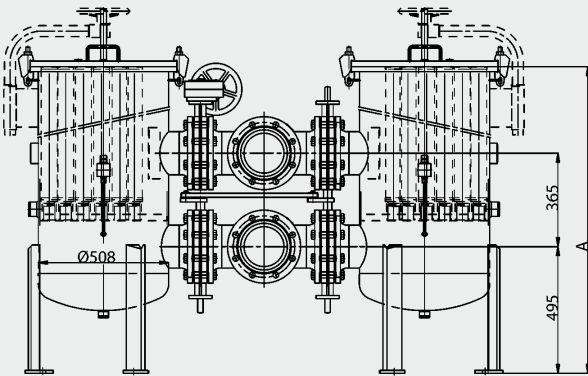

PMRFD 7

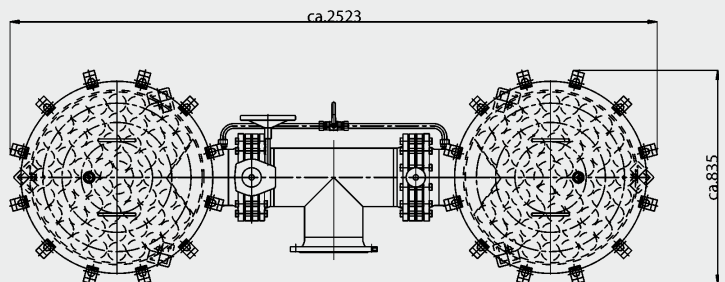
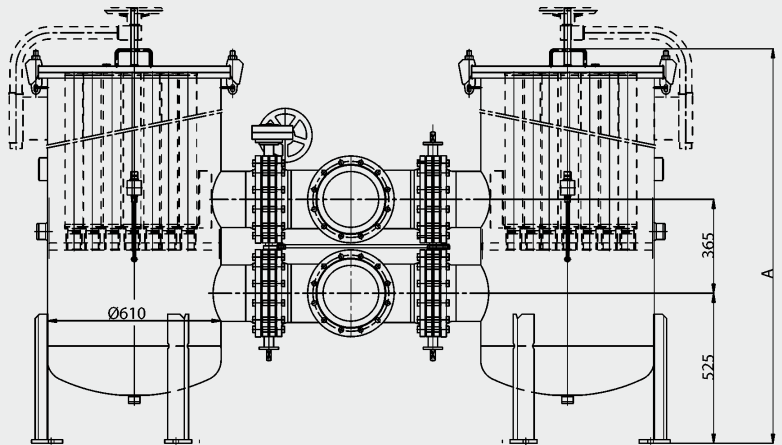

- The filter must not be used as a pipe support.
- The dimensions quoted have ± 5 mm tolerances for sizes up to 3.
- The dimensions quoted have ± 10 mm tolerances for sizes 4 upwards.

5.2 DIMENSIONS OF FLEXMICRON E ELEMENTS

Type 0: Compression ring (DOE), no cap or seal

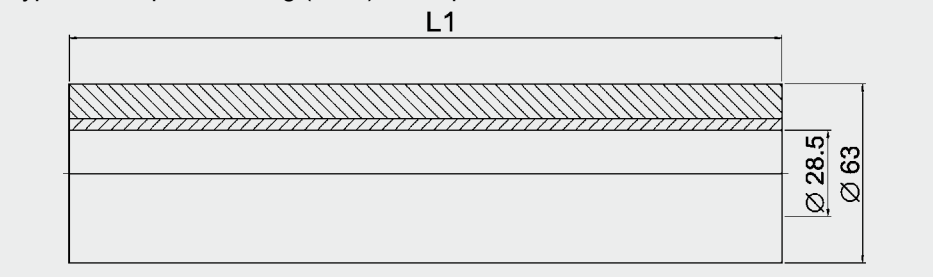

Type 1: Plug-in adapter (1 x 222 O-ring), flat end cap

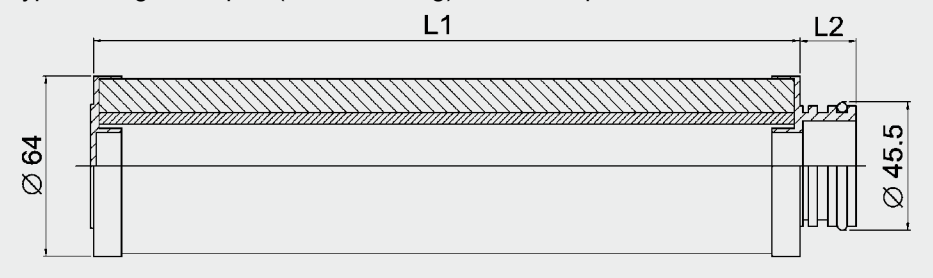

Type 2: Plug-in adapter (2 x 222 O-ring), flat end cap

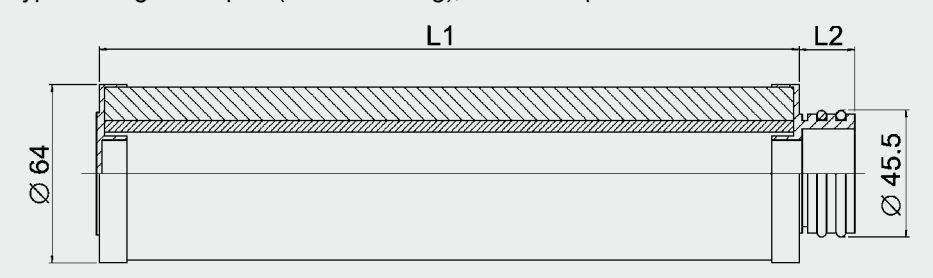

Type 10: Gasket (DOE)

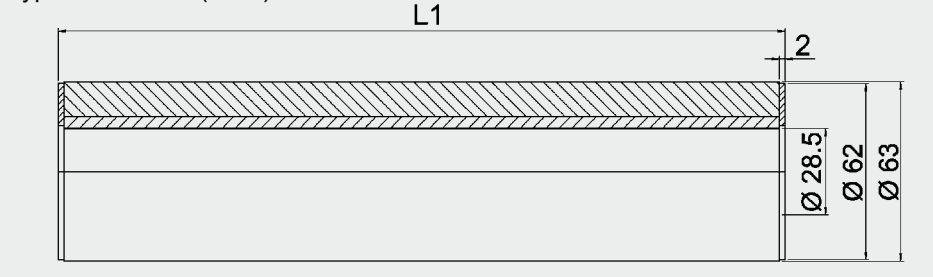

Type 13: Plug-in adapter (2x 222 O-ring), locating spigot

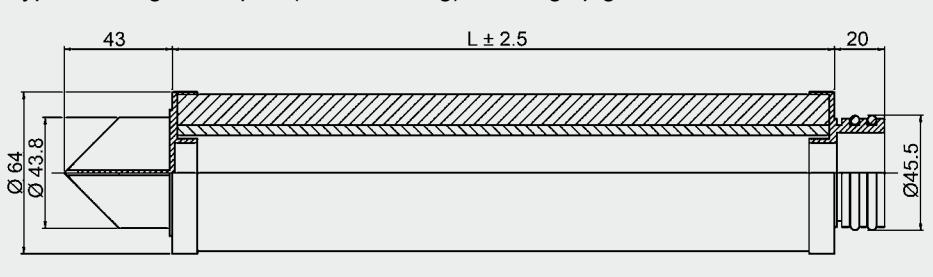

Type 14: Bayonet (2x 226 O-ring), locating spigot

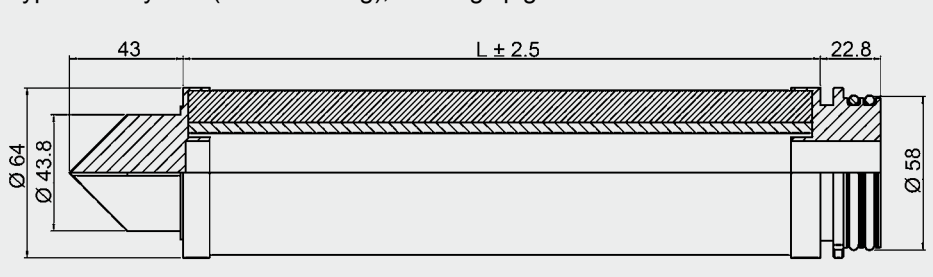

Code	L1 in mm
N10FM-E...	254
N20FM-E...	508
N30FM-E...	762
N40FM-E...	1016

Designation	L1 in mm	L2 in mm
N10FM-E...	254	20
N20FM-E...	508	20
N30FM-E...	762	20
N40FM-E...	1016	20

Designation	L1 in mm	L2 in mm
N10FM-E...	254	20
N20FM-E...	508	20
N30FM-E...	762	20
N40FM-E...	1016	20

Designation	L1 in mm
N10FM-E...	254
N20FM-E...	508
N30FM-E...	762
N40FM-E...	1016

Designation	L1 in mm	L2 in mm
N10FM-E...	254	43
N20FM-E...	508	43
N30FM-E...	762	43
N40FM-E...	1016	43

Designation	L1 in mm	L2 in mm
N10FM-E...	235	43
N20FM-E...	489	43
N30FM-E...	743	43
N40FM-E...	997	43

5.3 DIMENSIONS OF FLEXMICRON S ELEMENTS

Type 0: Compression ring (DOE), no cap or seal

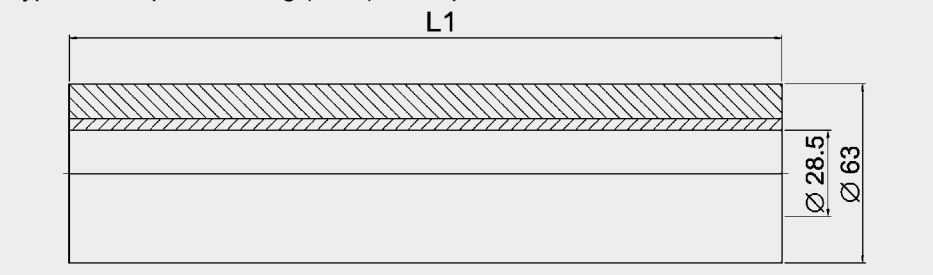

Type 1: Plug-in adapter (1 x 222 O-ring), flat end cap

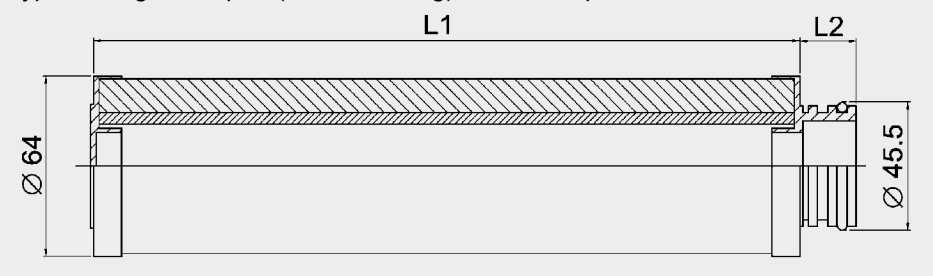

Type 2: Plug-in adapter (2 x 222 O-ring), flat end cap

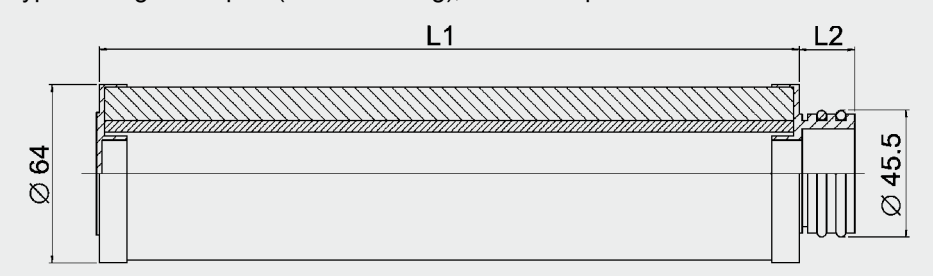

Type 10: Gasket (DOE)

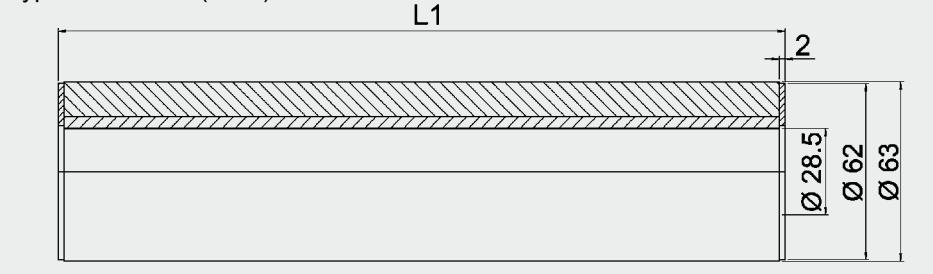

Type 13: Plug-in adapter (2x 222 O-ring), locating spigot

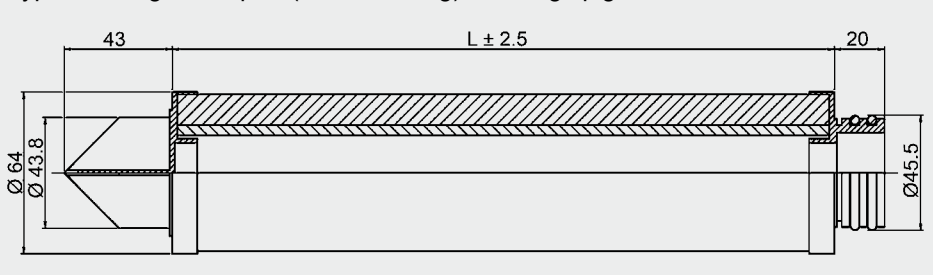

Type 14: Bayonet (2x 226 O-ring), locating spigot

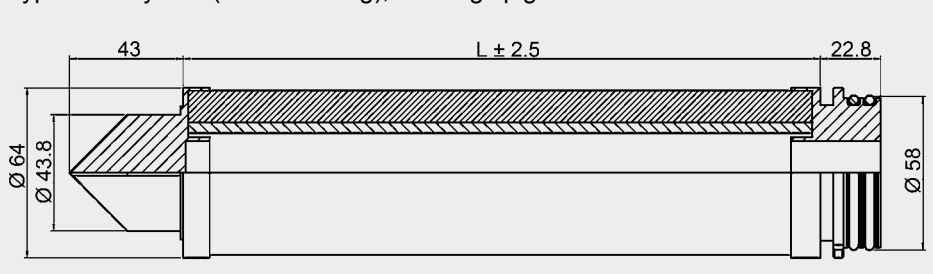

Code	L1 in mm
N10FM-S...	254
N20FM-S...	508
N30FM-S...	762
N40FM-S...	1016

Designation	L1 in mm	L2 in mm
N10FM-S...	254	20
N20FM-S...	508	20
N30FM-S...	762	20
N40FM-S...	1016	20

Designation	L1 in mm	L2 in mm
N10FM-S...	254	20
N20FM-S...	508	20
N30FM-S...	762	20
N40FM-S...	1016	20

Designation	L1 in mm
N10FM-S...	254
N20FM-S...	508
N30FM-S...	762
N40FM-S...	1016

Designation	L1 in mm	L2 in mm
N10FM-S...	254	43
N20FM-S...	508	43
N30FM-S...	762	43
N40FM-S...	1016	43

Designation	L1 in mm	L2 in mm
N10FM-S...	235	43
N20FM-S...	489	43
N30FM-S...	743	43
N40FM-S...	997	43

5.4 DIMENSIONS OF FLEXMICRON P (PREMIUM)

Type 1: Plug-in adapter (1 x 222 O-ring), flat end cap

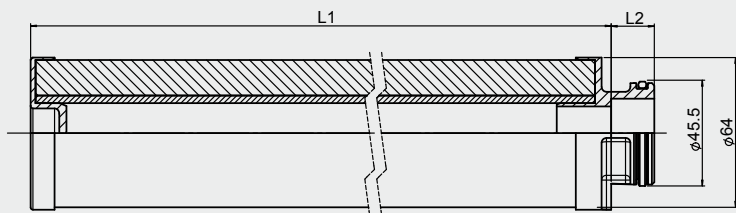

Type 2: Plug-in adapter (2 x 222 O-ring), flat end cap

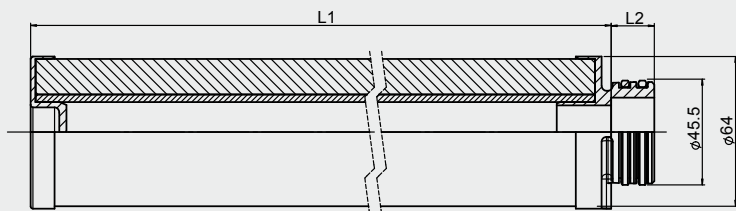

Type 3: Plug-in adapter (2 x 222 O-ring), flat end cap

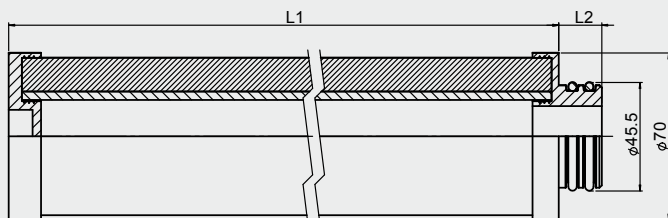

Type 5: Plug-in adapter (2x 222 O-ring), locating spigot

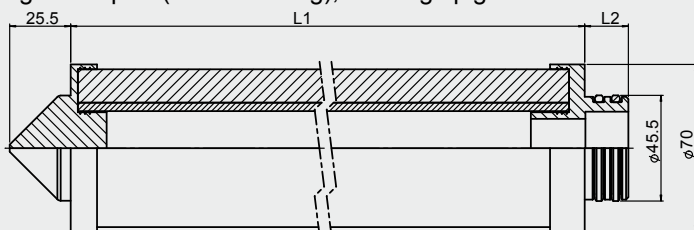

Type 7: Bayonet (2x 226 O-ring), locating spigot

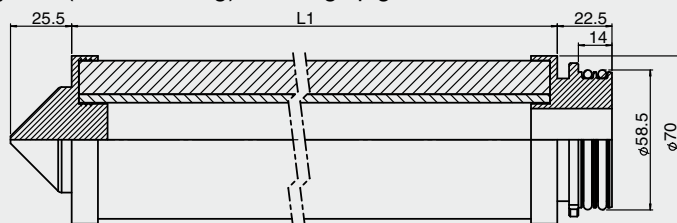

Type 10: Gasket (DOE), open

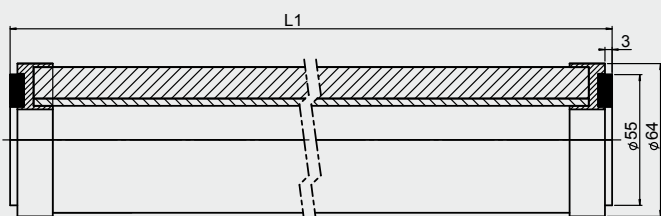

Type 12: Cuno adaptor (suspended elements)

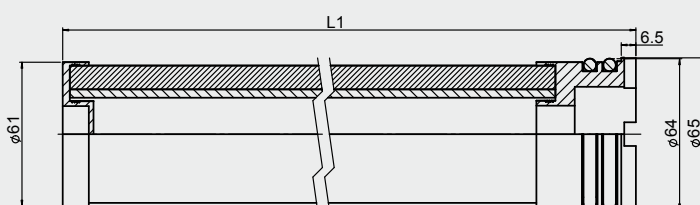

Code	L1 in mm	L2 in mm
N10MR-P...	263	18
N13MR-P...	339	18
N20MR-P...	517	18
N30MR-P...	771	18
N40MR-P...	1025	18

Designation	L1 in mm	L2 in mm
N10MR-P...	263	18
N13MR-P...	339	18
N20MR-P...	517	18
N30MR-P...	771	18
N40MR-P...	1025	18

Designation	L1 in mm	L2 in mm
N10FM-P...	263	18
N13FM-P...	339	18
N20FM-P...	517	18
N30FM-P...	771	18
N40FM-P...	1025	18

Designation	L1 in mm	L2 in mm
N10FM-P...	263	18
N13FM-P...	339	18
N20FM-P...	517	18
N30FM-P...	771	18
N40FM-P...	1025	18

Designation	L1 in mm
N10FM-P...	241
N13FM-P...	317
N20FM-P...	495
N30FM-P...	749
N40FM-P...	1003

Designation	L1 in mm
N10MR-P...	254
N13MR-P...	330
N20MR-P...	508
N30MR-P...	762
N40MR-P...	1016
N40MR-P...-990	988

Designation	L1 in mm
N37FM-P...	977

NOTE

The information in this brochure relates to the operating conditions and applications described.

For applications or operating conditions not described, please contact the relevant technical department.

Subject to technical modifications.

HYDAC Process Technology GmbH
Am Wrangelflöz 1
D-66538 Neunkirchen
Tel.: +49 (0)6897 - 509-1241
Fax: +49 (0)6897 - 509-1278
Internet: www.hydac.com
E-Mail: prozess-technik@HYDAC.com

E 7.713.1/04.14

