

2/2 Solenoid Directional Valve Poppet Type, Direct-Acting Normally Closed, Double-Blocking Screen Filter SAE-08 Cartridge – 250 bar WS08W-30

FUNCTION

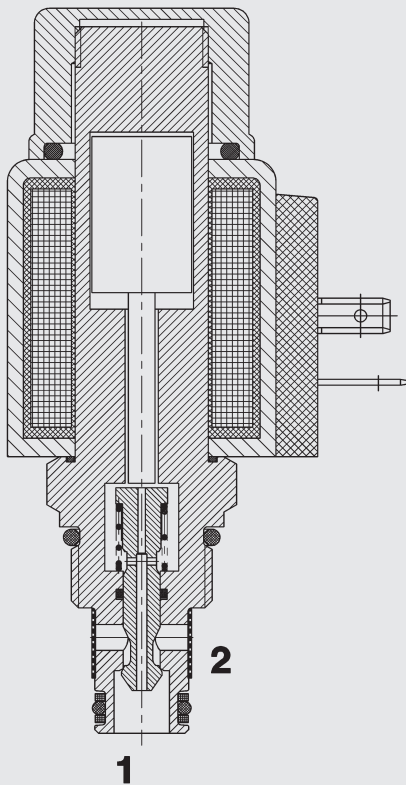

FEATURES

- Excellent switching performance by high power HYDAC solenoid
- Hardened and ground internal valve components to ensure minimal wear and extended service life
- External surfaces zinc-plated and corrosion-proof
- Wide variety of connectors available
- Low pressure drop due to CFD optimized flow path
- In flow direction 2 to 1 internal valve parts protected against coarse contamination by screen filter

SPECIFICATIONS

Operating pressure:	max. 250 bar	
Nominal flow:	max. 20 l/min	
Leakage:	Leakage-free (max. 5 drops \approx 0,25 cm ³ /min at 250 bar)	
Media operating temperature range:	min. -20 °C to max. +100 °C	
Ambient temperature range:	min. -20 °C to max. 60 °C	
Operating fluid:	Hydraulic oil to DIN 51524 Part 1 and 2	
Viscosity range:	min. 7.4 mm ² /s to max. 420 mm ² /s	
Filtration:	Class 21/19/16 according to ISO 4406 or cleaner	
Screen filter:	330 μ m mesh size	
MTTF _d :	150 years (see "Conditions and instructions for valves" in brochure 5.300)	
Installation:	No orientation restrictions	
Materials:	Valve body:	free-cutting steel
	Poppet:	hardened and ground steel
Seals:	NBR (standard) FKM (optional, media temperature range -20 °C to +120 °C)	
	Back-up rings:	PTFE
Coil:	steel / polyamide	
Cavity:	FC08-2	
Weight:	Valve complete	0.33 kg
	Coil only	0.19 kg

Electrical data:

Coil duty rating:	Continuous up to max. 115% of the nominal voltage at 60 °C ambient temperature	
Current draw at 20 °C:	1.5 A at 12 V DC	
	0.8 A at 24 V DC	
Voltage tolerance:	\pm 15% of the nominal voltage	
	Response time:	Energized: approx. 35 ms De-energized: approx. 50 ms
Coil type:	Coil...-40-1836	

When the solenoid coil is de-energized, the valve blocks flow in both directions.
When energized the valve allows flow in both directions.

DIMENSIONS

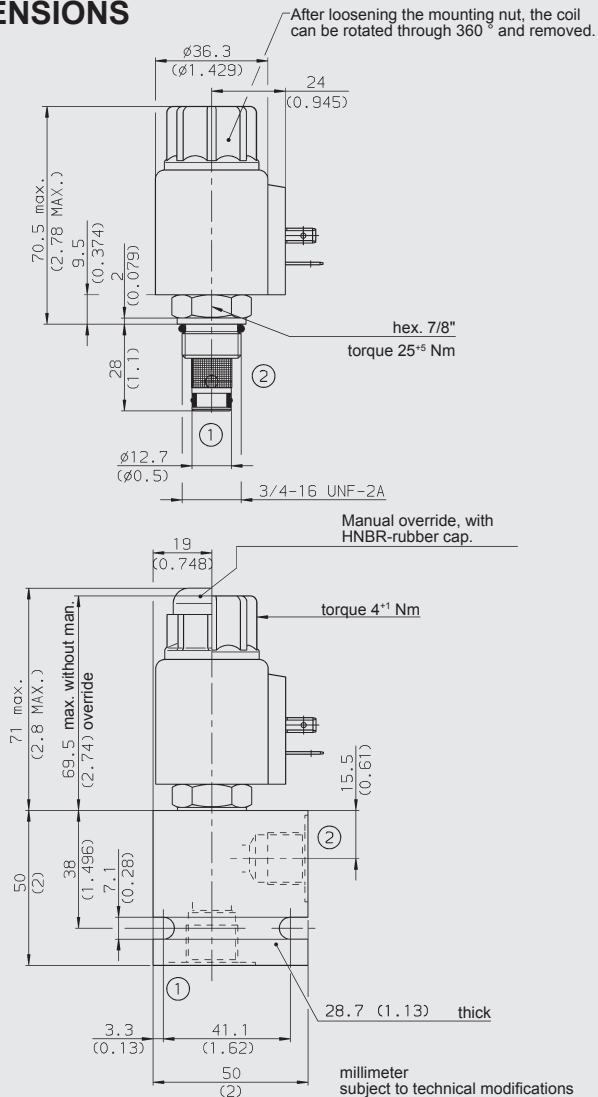

MODEL CODE

WS08W-30 M - C - N - 24 DG

Basic model

Directional poppet valve, UNF, with screen filter

Manual override

No details = without manual override

M = manual override

Body and ports*

C = cartridge only

SB3 = G3/8 ports, steel body

AB3 = G3/8 ports, aluminium body

Seals

N = NBR (standard)

V = FKM

Coil voltage

DC voltages

12 = 12 V DC

24 = 24 V DC

AC voltages (bridge rectifier built into the coil)

115 = 115 V AC

230 = 230 V AC

Other voltages on request

Coil connectors (type 40-1836)

DC: DG = DIN connector to EN 175301-803

DK = KOSTAL threaded connection M27x1

DL = 2 flying leads, 457 mm long, 0.75 mm²

DN = Deutsch connector, 2-pole, axial

DT = AMP Junior Timer, 2-pole, radial

AC: AG = DIN connector to EN 175301-803

Other connectors on request

Standard models

Model code	Part No.
WS08W-30-C-N-24DG	3132864
WS08W-30-C-N-230AG	3132865

*Standard in-line bodies

Code	Part No.	Material	Ports	Pressure
FH082-SB3	560919	Steel, zinc-plated	G3/8	420 bar
FH082-AB3	3011423	Aluminium, anodized	G3/8	210 bar

Other line bodies on request

Seal kits

Code	Material	Part No.
FS082-N SEAL KIT	NBR	3033920
FS082-V SEAL KIT	FKM	3051756

CAVITY

FC08-2

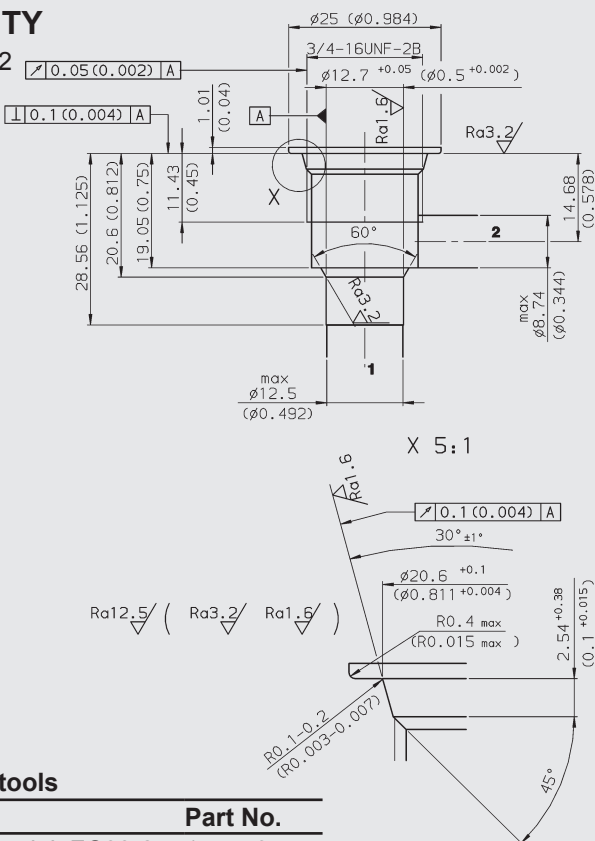

Form tools

Tool	Part No.
Countersink FC08-2	175473
Reamer FC08-2	175474

millimeter subject to technical modifications

PERFORMANCE

Measured at $v = 33 \text{ mm}^2/\text{s}$, $T_{\text{oil}} = 46 \text{ }^\circ\text{C}$

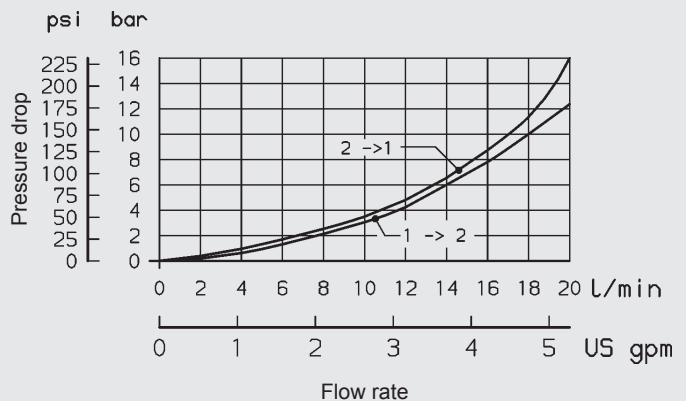

NOTE

The information in this brochure relates to the operating conditions and applications described. For applications or operating conditions not described, please contact the relevant technical department. Subject to technical modifications.

HYDAC Fluidtechnik GmbH

Justus-von-Liebig-Str.
D-66280 Sulzbach/Saar
 Tel: 0 68 97 /509-01
 Fax: 0 68 97 /509-598
 E-Mail: flutec@hydac.com