

FUNCTION

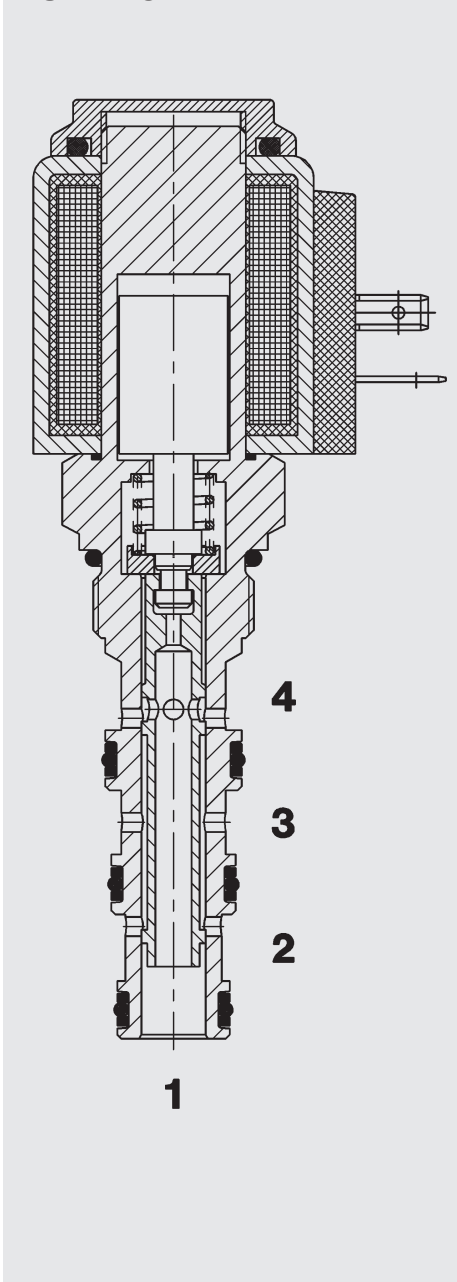

When the solenoid coil is de-energised, the valve allows flow from port 3 to 2 or 2 to 3 and from port 4 to 1 and 1 to 4.

When energised, the valve allows flow from port 3 to 4 or 4 to 3 and from port 2 to 1 and 1 to 2.

4/2 Solenoid Directional Valve Spool Type, Direct-Acting, Metric Cartridge – 350 bar WKM08140X-01

FEATURES

- Coil seals protect the solenoid system
- Wide variety of connectors available
- Hardened and ground control spool to ensure minimal wear and extended service life
- Low pressure drop due to CFD optimized flow path
- External surfaces zinc-plated and corrosion-proof
- Excellent stability throughout the entire flow range
- Compact design enables space-saving installation in connection housings and control blocks

SPECIFICATIONS

Operating pressure:	max. 350 bar
Nominal flow:	max. 25 l/min
Internal leakage:	max. 150 cm ³ /min at 250 bar and 34 mm ² /s
Media operating temperature range:	min. -20 °C to max. +100 °C
Ambient temperature range:	min. -20 °C to max. +60 °C
Operating fluid:	Hydraulic oil to DIN 51524 Part 1 and 2
Viscosity range:	min. 10 mm ² /s to max. 420 mm ² /s
Filtration:	Class 21/19/16 according to ISO 4406 or cleaner
MTTF _d :	150 years (see "Conditions and instructions for valves" in brochure 5.300)
Installation:	No orientation restrictions
Materials:	Valve body: free-cutting steel Spool: hardened and ground steel Seals: NBR (standard) FKM (optional, media temperature range -20 °C to +120 °C) Back-up rings: PTFE Coil: steel / polyamide
Cavity:	08140
Weight:	Valve complete 0.38 kg Coil only 0.19 kg

Electrical data:

Type of voltage:	DC solenoid, AC voltage is rectified using a bridge rectifier built into the coil
Current draw at 20 °C:	1.5 A at 12 V DC 0.8 A at 24 V DC
Voltage tolerance:	± 15% of the nominal voltage
Coil duty rating:	100% (continuous) up to max. 115% of the nominal voltage at 60 °C ambient temperature
Coil type:	Coil...-40-1836

