

4/2 Solenoid Directional Valve **UNF** Spool Type, Direct-Acting SAE-10 Cartridge – 350 bar

WK10N-01

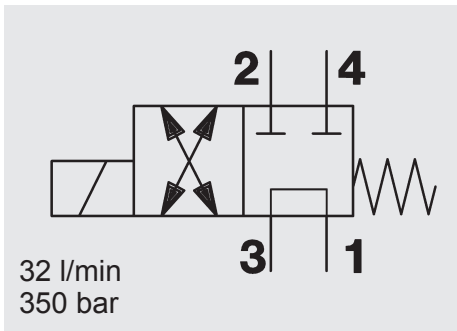

FUNCTION

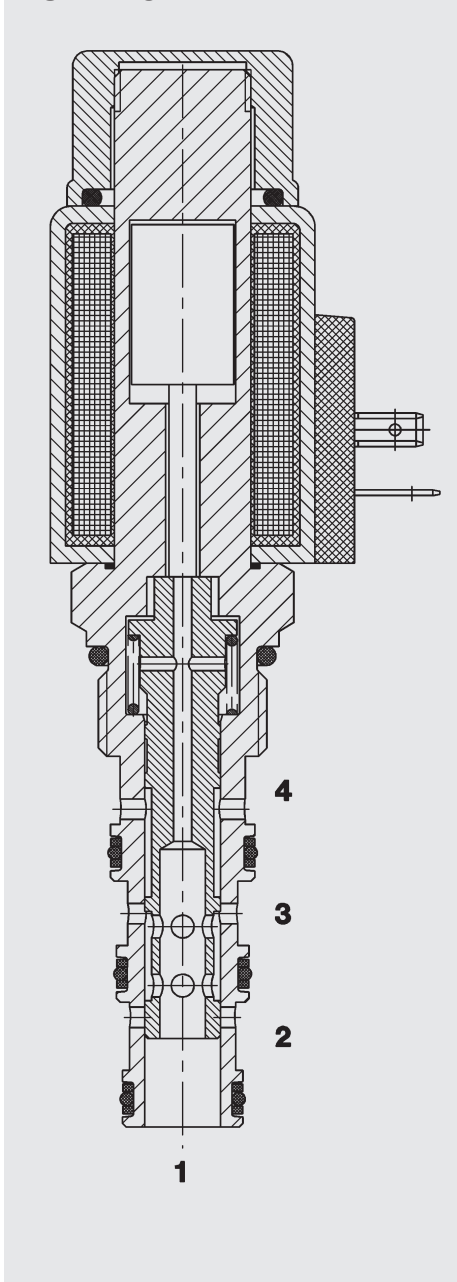

When de-energized, the valve allows flow from port 3 to 1 or from 1 to 3, while blocking flow at ports 2 and 4.

When energized, the valve allows flow from port 3 to 4 or from 4 to 3 and from port 1 to 2 or 2 to 1.

FEATURES

- External surfaces zinc-plated and corrosion-proof
- Hardened and ground internal valve components to ensure minimal wear and extended service life
- Coil seals protect the solenoid system
- Wide variety of connectors available
- Excellent switching performance by high power HYDAC solenoid
- Low pressure drop due to CFD optimized flow path

SPECIFICATIONS

Operating pressure:	350 bar
Nominal flow:	32 l/min
Internal leakage:	max. 140 cm ³ /min at 250 bar and 34 mm ² /s
Media operating temperature range:	min. -20 °C to max. +100 °C
Ambient temperature range:	min. -20 °C to max. +60 °C
Operating fluid:	Hydraulic oil to DIN 51524 Part 1 and 2
Viscosity range:	min. 7.4 mm ² /s to max. 420 mm ² /s
Filtration:	Class 21/19/16 according to ISO 4406 or cleaner
Installation:	No orientation restrictions
Material:	Valve body: free-cutting steel Spool: hardened and ground steel Seals: NBR (standard) FKM (optional, media temperature range -20 °C to 120 °C) Back-up rings: PTFE Coil: steel / polyamide
Cavity:	FC10-4
Weight:	Valve complete: 0.48 kg Coil only: 0.23 kg

Electrical data:

Type of voltage:	DC solenoid, AC voltage is rectified using a bridge rectifier built into the coil
Current draw at 20 °C:	2.22 A at 12 V DC 1.13 A at 24 V DC
Voltage tolerance:	± 15% of the nominal voltage
Coil duty rating:	Continuous up to max. 115% of the nominal voltage at max. 60° C ambient temperature
Coil type:	Coil...-50-1836

