

FUNCTION

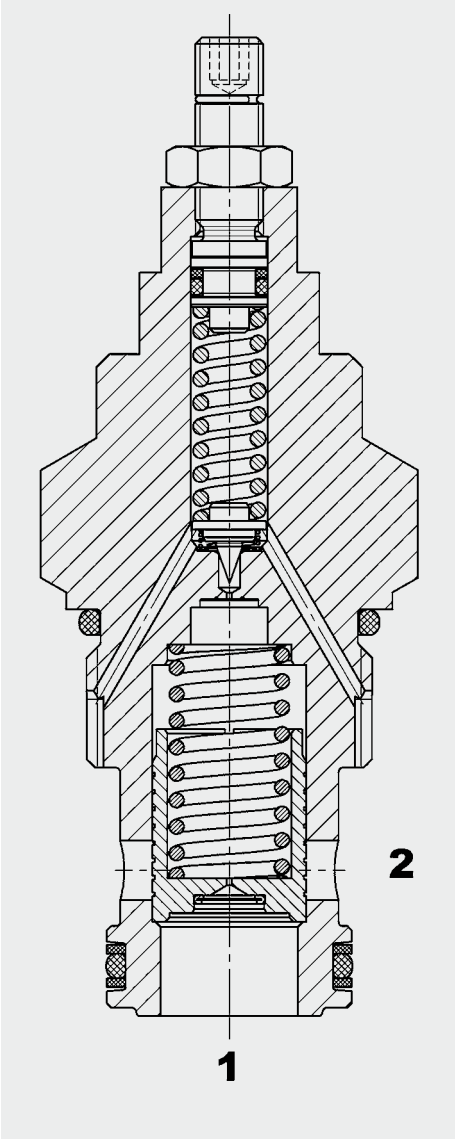

The DB16P is a pilot-operated, spool type pressure relief valve. If the pressure at port 1 exceeds the pressure setting, the pilot poppet opens, creating a small flow over the orifice of the pilot stage to the tank. The pressure drop across the orifice lifts the main spool against a light spring, opening the connection between port 1 and port 2.

FEATURES

- External surfaces zinc-plated and corrosion-proof
- Hardened and ground internal valve components to ensure minimal wear and extended service life
- Excellent stability throughout the entire flow range
- Low pressure drop due to CFD optimized flow path
- Screen protected metering orifice enhances safety
- Optional spring ranges up to 345 bar
- Adjustable throughout flow range
- Quick response

SPECIFICATIONS

Operating pressure:	max. 350 bar
Nominal flow:	max. 300 l/min
Operating pressure ranges:	5 to 35 bar 5 to 60 bar 5 to 125 bar 5 to 230 bar 5 to 345 bar
Internal leakage:	max. 1300 ml/min at 80 % of $p_{Nom. pressure}$
Media operating temperature range:	min. -30 °C to max. +100 °C
Ambient temperature range:	min. -30 °C to max. +100 °C
Operating fluid:	Hydraulic oil to DIN 51524 Part 1 and 2
Viscosity range:	min. 7.4 mm ² /s to max. 420 mm ² /s
Filtration:	Class 21/19/16 to ISO 4406 or cleaner
Installation:	No orientation restrictions
Materials:	Valve body: free-cutting steel Spool: hardened and ground steel Seals: NBR (standard) FKM (optional, media temperature range -20 °C to +120 °C) Support rings PTFE
Cavity:	FC16-2
Weight:	0.47 kg

DIMENSIONS

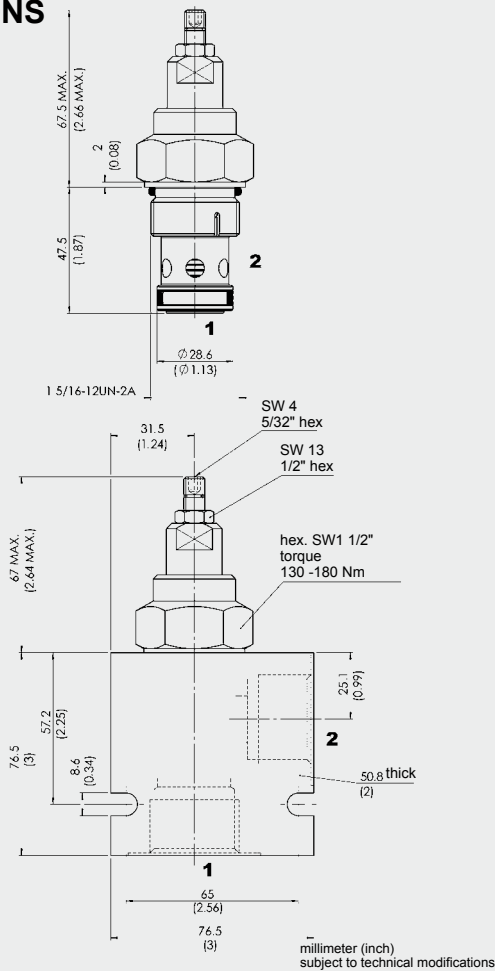

MODEL CODE

DB16P-01 - C - N - 180 V 100

Basic model

Pressure relief valve, UNF

Body and Ports*

C = Cartridge only

SB8 = G1 ports, steel body

AB8 = G1 ports, aluminium body

Seals

N = NBR

V = FKM

Setting pressure range

050 = 5 to 35 bar

090 = 5 to 62 bar

180 = 5 to 124 bar

330 = 5 to 228 bar

500 = 5 to 345 bar

Other pressure ranges on request

Type of adjustment

V = Allen head (hex. 5/32")

H = Knob adjustment

F = Factory preset, non adjustable

K = Allen head (hex. 5/32") with protective cap

Opening pressure setting

No details = no setting, spring relaxed

100 = customer-specific opening pressure on request

Standard models

Model code	Part No.
DB16P-01-C-N-090V	3010799
DB16P-01-C-N-330V	3010800
DB16P-01-C-N-500V	3010794

*Standard in-line bodies

Code	Part No.	Material	Ports	Pressure
FH162-SB8	3032496	Steel, zinc-plated	G1	420 bar
FH162-AB8	3037193	Aluminium, anodized	G1	210 bar

Seal kits

Code	Material	Part No.
FS162-N Seal Kit	NBR	3052427
FH162-V Seal kit	FKM	3051758

CAVITY

FC16-2

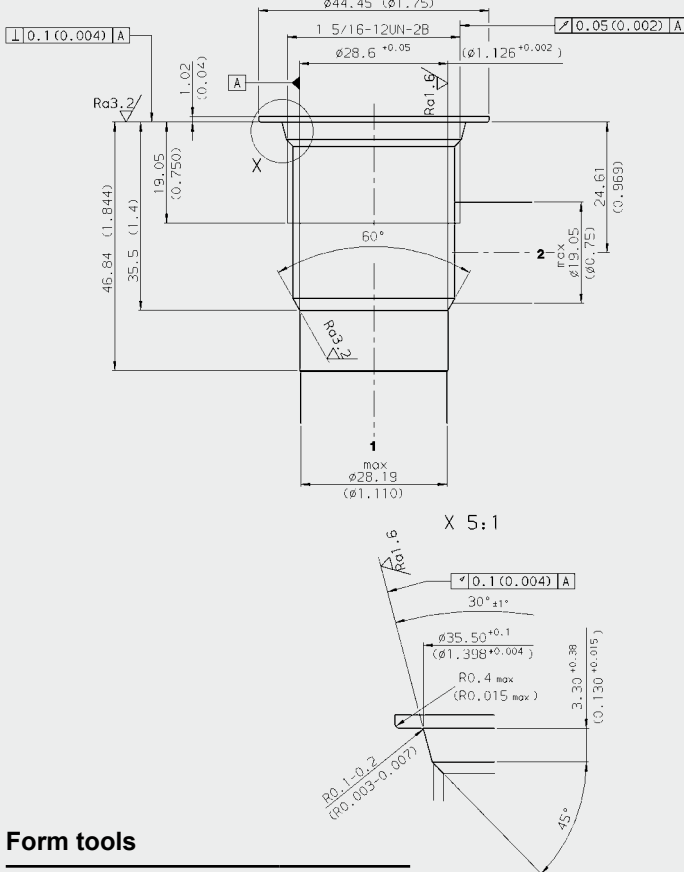

Form tools

Tool	Part No.
Rougher FC16-2	176218
Reamer FC16-2	176219

millimeter (inch)
subject to technical modifications

PERFORMANCE

Measured at $v = 34 \text{ mm}^2/\text{s}$, $T_{\text{Oil}} = 46^\circ\text{C}$

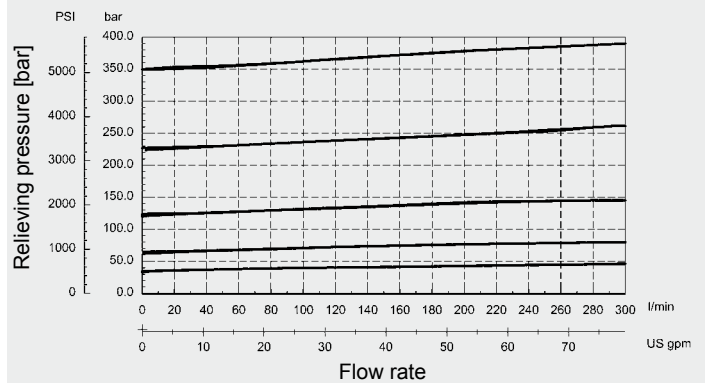

Note

The information in this brochure relates to the operating conditions and applications described. For applications or operating conditions not described, please contact the relevant technical department. Subject to technical modifications.

HYDAC Fluidtechnik GmbH

Justus-von-Liebig-Str.
D-66280 Sulzbach/Saar
Tel: 0 68 97 /509-01
Fax: 0 68 97 /509-598
E-Mail: flutec@hydac.com