

FUNCTION

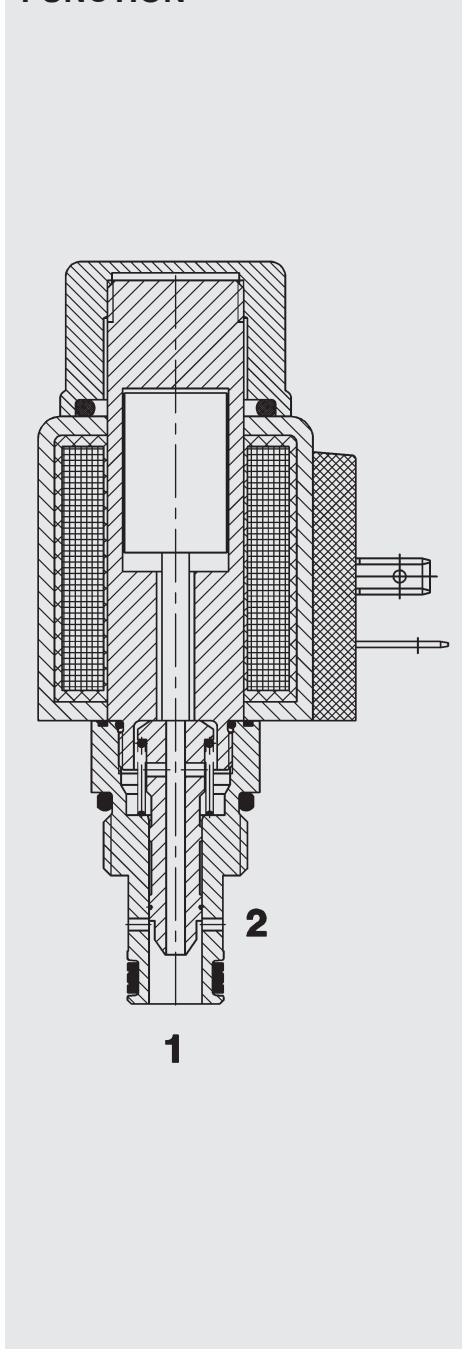

When the solenoid coil is de-energized, the valve is open in both directions.
When the solenoid coil is energized, the valve is closed in both directions.

2/2 Solenoid Directional Valve **UNF** Spool Type, Direct-Acting SAE-08 Cartridge – 350 bar WK08V-01

FEATURES

- External surfaces zinc-plated and corrosion-proof
- Hardened and ground internal valve components to ensure minimal wear and extended service life
- Coil seals protect the solenoid system
- Wide variety of connectors available
- Excellent switching performance by high power HYDAC solenoid
- Low pressure drop due to CFD optimized flow path

SPECIFICATIONS

Operating pressure:	max. 350 bar	
Nominal flow:	max. 19 l/min	
Internal leakage:	90 cm ³ /min at 250 bar and 34 mm ² /s	
Media operating temperature range:	min. -20 °C to max. +100 °C	
Ambient temperature range:	min. -20 °C to max. +60 °C	
Operating fluid:	Hydraulic oil to DIN 51524 Part 1 and 2	
Viscosity range:	min. 7.4 mm ² /s to max. 420 mm ² /s	
Filtration:	Class 21/19/16 according to ISO 4406 or cleaner	
MTTF _d :	150 years (see "Conditions and instructions for valves" in brochure 5.300)	
Installation:	No orientation restrictions	
Materials:	Valve body:	free-cutting steel
	Spool:	hardened and ground steel
	Seals:	NBR (standard) FKM (optional, media temperature range -20 °C to +120 °C)
	Back-up rings:	PTFE
	Coil:	steel / polyamide
Cavity:	FC08-2	
Weight:	Valve complete	0.36 kg
	Coil only	0.19 kg
Electrical data:		
Type of voltage:	DC solenoid, AC voltage is rectified using a bridge rectifier built into the coil	
Current draw at 20 °C:	1.5 A at 12 V DC 0.8 A at 24 V DC	
Voltage tolerance:	± 15% of the nominal voltage	
Coil duty rating:	Continuous up to max. 115% of the nominal voltage at 60 °C ambient temperature	
Coil type:	Coil...-40-1836	

DIMENSIONS

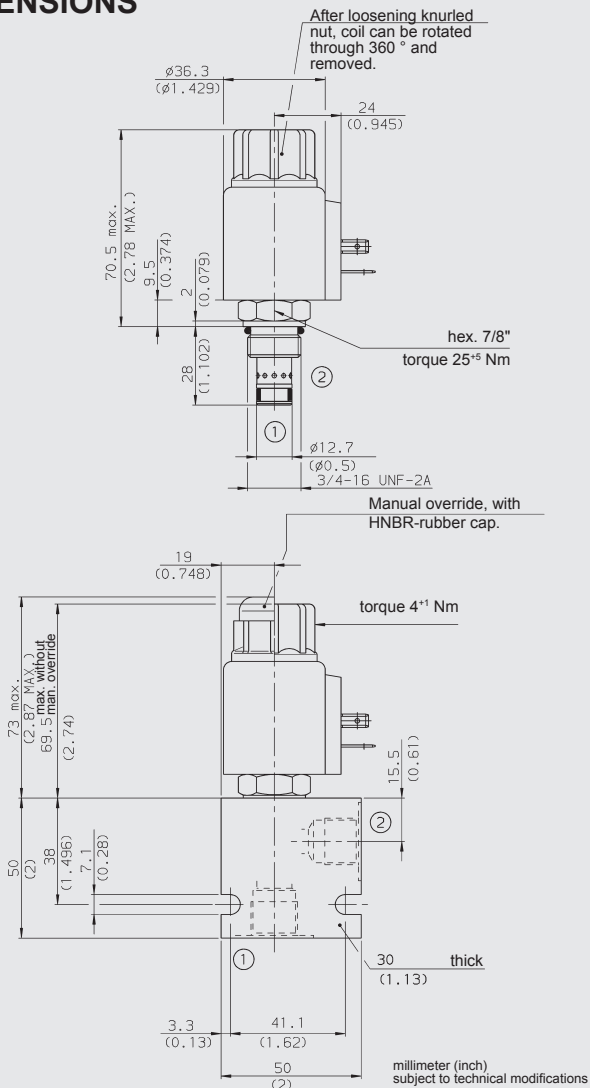

MODEL CODE

WK08V-01 M-C-N-24 DG

Basic model

Directional spool valve, UNF

Type

01 = standard

Manual override

No details = without manual override

M = manual override

Body and ports*

C = cartridge only

SB3 = G3/8 ports, steel body

AB3 = G3/8 ports, aluminium body

Seals

N = NBR (standard)

V = FKM

Coil voltage

DC voltages:

12 = 12 V DC

24 = 24 V DC

AC voltages (bridge rectifier built into the coil)

115 = 115 V AC

230 = 230 V AC

Other voltages on request

Coil connectors (type 40-1836)

DC: DG = DIN connector to EN 175301-803

DK = KOSTAL threaded connection M27x1

DL = 2 flying leads, 457 mm long, 0.75 mm²

DN = Deutsch connector, 2-pole, axial

DT = AMP Junior Timer, 2-pole, radial

AC: AG = DIN connector to EN 175301-803

Other connectors on request

Standard models

Model Code	Part No.
WK08V-01-C-N-24DG	3020235
WK08V-01-C-N-230AG	3044018
Other models on request	

*Standard in-line bodies

Code	Part No.	Material	Ports	Pressure
FH082-SB3	560919	Steel, zinc-plated	G3/8	420 bar
FH082-AB3	3011423	Aluminium, clear anodized	G3/8	210 bar
Other line bodies on request				

Seal kits

Code	Material	Part No.
FS082-N SEAL KIT	NBR	3033920
FS082-V SEAL KIT	FKM	3051756

CAVITY

FC08-2

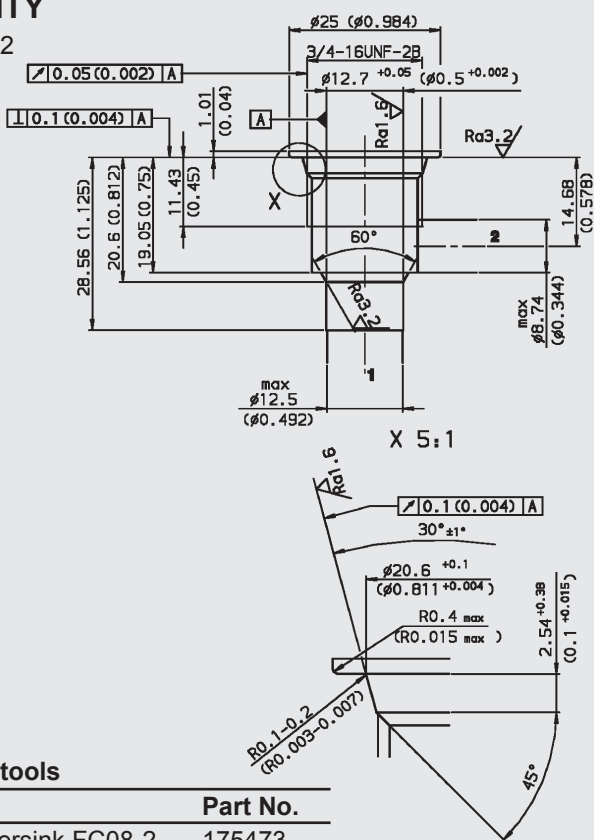

Form tools

Tool	Part No.
Countersink FC08-2	175473
Reamer FC08-2	175474

PERFORMANCE

Measured at $v = 34 \text{ mm}^2/\text{s}$, $T_{oil} = 46 \text{ }^\circ\text{C}$

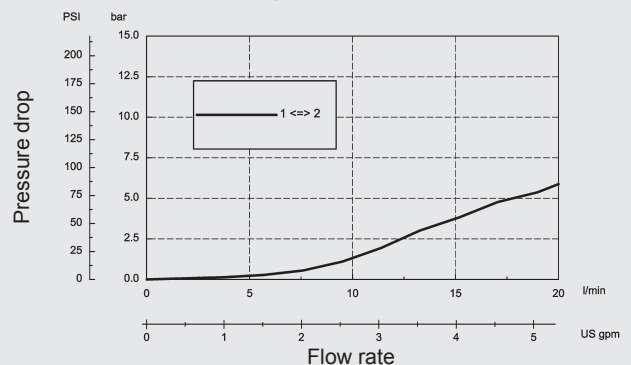

NOTE

The information in this brochure relates to the operating conditions and applications described. For applications or operating conditions not described, please contact the relevant technical department. Subject to technical modifications.

HYDAC Fluidtechnik GmbH

Justus-von-Liebig-Str.

D-66280 Sulzbach/Saar

Tel: 0 68 97 /509-01

Fax: 0 68 97 /509-598

E-Mail: flutec@hydac.com