

Flow rate transmitter HFT 2500

For water or water-based fluids

Float

Any installation

Two accuracy classes

Features

- Analogue signal selectable:
4 .. 20 mA or 0 .. 10 V
- Wide measuring range
- Robust design
- High operating pressures

Description

The HYDAC HFT 2500 flow transmitter series is based on a position-independent float measuring principle.

Irrespective of the installation position, the test medium deflects a spring-loaded float in the direction of flow, depending on the flow rate.

A Hall sensor is fitted to the outside of the device and is therefore also separated from the flow circuit. In proportion to the deflection of the float, the sensor produces an analogue signal, either 4 .. 20 mA or 0 .. 10 V, which corresponds with the particular measuring range.

The instrument is calibrated for vertical installation and for a flow direction from bottom to top (maximum accuracy).

Application fields

Fields of application are flow rate monitoring in fluids (water / water-based) in the following areas, amongst others:

- Cooling systems and circuits
- Hydraulic systems
- Pumps
- Welding machines and laser systems
- Medical engineering
- Pharmaceutical industry
- Chemical industry
- Research and development

Technical details

Input data					
Measuring ranges [l/min]	10 % accuracy			5% accuracy	
	Size 1	Size 2	Size 3	Size 4	
	0.005 .. 0.06	0.02 .. 0.2	10 .. 30	0.2 .. 4.0	8 .. 90
	0.04 .. 0.13	0.2 .. 0.6	15 .. 45	0.6 .. 5.0	5 .. 110
	0.1 .. 0.6	0.4 .. 1.8	20 .. 60	0.5 .. 8.0	10 .. 150
	0.2 .. 1.2	0.8 .. 3.2	30 .. 90	1 .. 14	35 .. 220
	0.4 .. 2.0	2 .. 7	60 .. 150	1 .. 28	35 .. 250
	0.5 .. 3.0	3 .. 13		2 .. 40	
	4 .. 20		4 .. 55		
	8 .. 30		1 .. 70		
Operating pressure Brass version [bar] Stainless steel version [bar]	300 350	300 350	250 300	200 300	
Pressure drop [bar]	0.02 .. 0.2	0.02 .. 0.3	0.02 .. 0.4	0.02 .. 0.8	
Mechanical Connection	See device dimensions / installation dimensions				
Parts in contact with fluid Brass version Stainless steel version	Stainless steel 1.4571; Brass; nickel-plated; Brass; Hard ferrite; Seal: NBR ¹⁾ Stainless steel 1.4571; Hard ferrite; seal: Viton ¹⁾				
Housing material Measuring body Transmitter	Brass nickel-plated or stainless steel 1.4571 Brass				
Output data					
Output signal	Max. load resist. Max. current	4 .. 20 mA, 3 conductor, R _{Lmax} ~ 600 Ω 0 .. 10 V, 3 conductor, I _{max} ~ 10 mA			
Accuracy	≤ ± 10 % FS / ≤ ± 5 % FS (size 4)				
Repeatability	2 % FS max.				
Environmental Conditions					
Operating temperature range	-20 .. +70 °C				
Fluid temperature range	-20 .. +70 °C				
CE mark	2014/30/EU 2011/65/EU 2015/863/EU				
protection type to DIN EN 60529 ²⁾	IP 65 / IP 67				
Other data					
Supply voltage	24 V DC (19 – 30 V DC)				
Power consumption	< 1 W				
Weight	See device dimensions / installation dimensions				

Note: **FS (Full Scale)** = relative to complete measuring range

- 1) Other seal materials on request
- 2) With mating connector of corresponding protection type fitted

Dimensions

Size 1

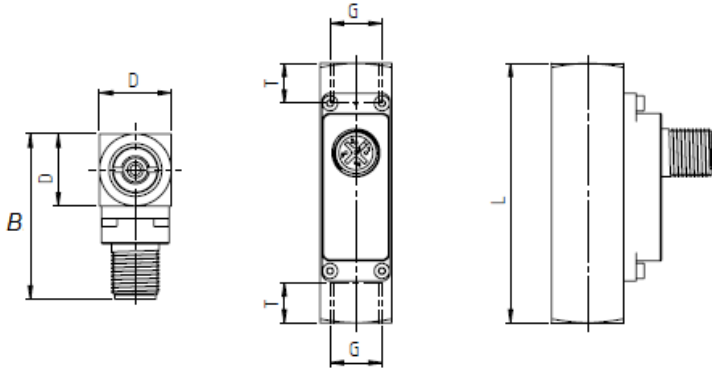

Type [l/min]	Installation dimensions [mm]							Weight, approx. [g]
	SW	D	B	G	DN	T	L	
Size 1								
0.005 .. 0.06	17	17	40	1/4"	8	10	65	140
0.04 .. 0.13								
0.1 .. 0.6								
0.2 .. 1.2								
0.4 .. 2.0								
0.5 .. 3.0								
1.0 .. 5.0								

Size 2

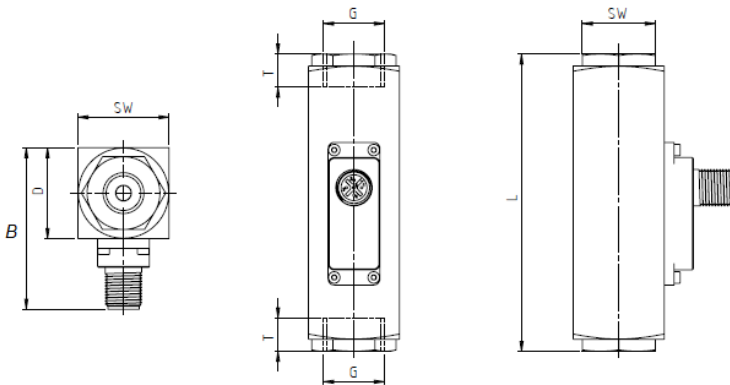

Type [l/min]	Installation dimensions [mm]							Weight, approx. [g]
	SW	D	B	G	DN	T	L	
Size 2								
0.02 .. 0.2	30	30	53	1/2"	15	14	90	520
0.2 .. 0.6								
0.4 .. 1.8								
0.8 .. 3.2								
2.0 .. 7.0								
3.0 .. 13.0								
4.0 .. 20.0								
8.0 .. 30.0								

Size 3

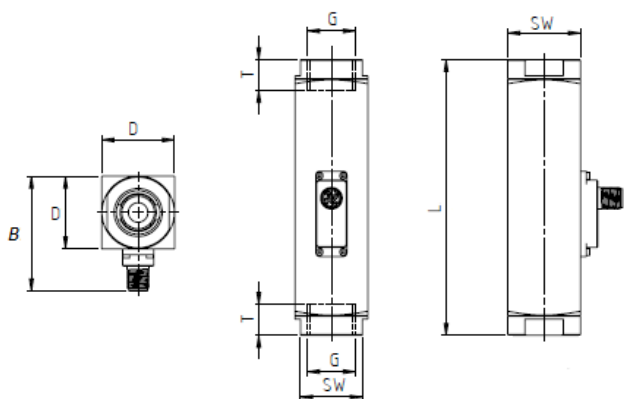

Type [l/min]	Installation dimensions [mm]							Weight, approx. [g]
	SW	D	B	G	DN	T	L	
Size 3								
10 .. 30	34 40	40	63	3/4" 1" *	20 25	15 17	152 130	1290 1110
15 .. 45								
20 .. 60								
30 .. 90	40	40	63	1"	25	17	130	1110
60 .. 150	40	40	63	1"	25	17	130	1050

* Standard

Size 4

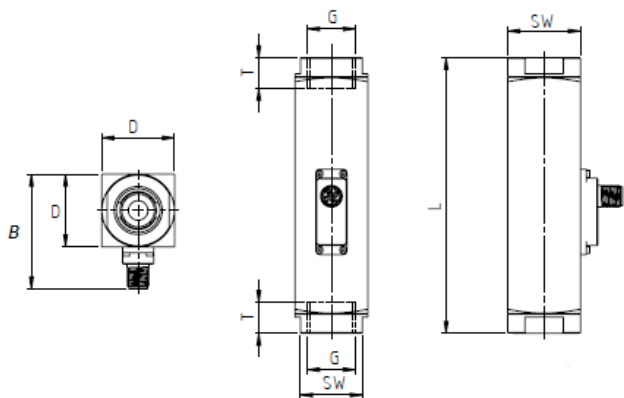

Type [l/min]	Installation dimensions [mm]							Weight, approx. [g]
	SW	D	B	G	DN	T	L	
Size 4								
0.2 .. 4.0	27	30	53	1/4" 3/8" 1/2"	8 10 15	10 15 14	131	850
0.6 .. 5.0								
0.5 .. 8.0								
1 .. 14								
1 .. 28								
2 .. 40	27	30	53	1/2"	15	14	146	900
4 .. 55								
1 .. 70	34 40	40 40	63 63	3/4" 1"	20 25	15 17	152 156	1400 1100
8 .. 90								
5 .. 110								
10 .. 150	50	50	73	1 1/4"	32	20	200	2750
35 .. 220	50	50	73	1 1/4"	32	20	200	3000
35 .. 250	60	60	83	1 1/2"	40	20	200	3800

Pin connections

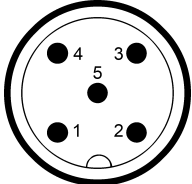
M12x1, 5 pin	Pin	Output signal: BC
	1	+U _B
	2	4 .. 20 mA
	3	GND
	4	0 .. 10 V
	5	reserved

Model code

HFT 2 5 X 8 - BC - XXXX-XXXX - X - X - X - 000

Measurement procedure

2 = Variable area float

Measuring fluid

5 = Water or water-based

Mechanical connection ^{1) 2)}

1 = 1/4"

2 = 3/8"

3 = 1/2"

4 = 3/4"

5 = 1"

6 = 1 1/4"

7 = 1 1/2"

Electrical connection

8 = Plug M12X1, 5 pin (mating connector not included)

Output signal

BC = Both signals B = 0 .. 10 V and C = 4 .. 20 mA

Measuring ranges l/mi²

Size 1

.005-0.06; 0.04-0.13; 00.1-00.6; 00.2-01.2; 00.4-02.0; 00.5-03.0; 01.0-05.0

Size 2

0.02-00.2; 00.2-00.6; 00.4-01.8; 00.8-03.2; 02.0-07.0; 03.0-0013;
04.0-0020; 08.0-0030

Size 3

0010-0030; 0015-0045; 0020-0060; 0030-0090; 0060-0150

Size 4

00.2-04.0; 00.6-05.0; 00.5-08.0; 01.0-0014; 01.0-0028; 02.0-0040; 04.0-0055;
01.0-0070; 08.0-0090; 0005-0110; 0010-0150; 0035-0220; 0035-0250

Accuracy

6 = ≤ 5.0 % FS (for size 4 only)

7 = ≤ 10.0 % FS

Housing material

B = Brass, nickel-plated

S = Stainless steel

Mechanical indicator

0 = Without display

1 = With display

Modification number

000 = Standard

¹⁾ Mechanical connection options depend on housing type (see Dimensions)

²⁾ Other models available on request

Accessories:

Appropriate accessories, such as mating connectors, can be found in the Accessories brochure.

Note

The information in this brochure relates to the operating conditions and applications described.
For applications or operating conditions not described, please contact the relevant technical department.
Subject to technical modifications.

HYDAC ELECTRONIC GMBH
Hauptstraße 27
66128 Saarbrücken/Germany
Telephone +49 (0)6897 509-01
Fax +49 (0)6897 509-1726
E-mail: electronic@hydac.com
Internet: www.hydac.com