

HYDAC INTERNATIONAL

**Hydraulic Controls
for Attachments**



Working with Attachments

For the control of attachments like hammers, 4in1 buckets, cutters, rippers, grapples, etc. as well as their suspension via adaptor plate, quick coupler and/or tilt rotator HYDAC offers different hydraulic controls:

- **Quick coupler control – for changing attachments (also fully automatic)**
- **Pressure adjustment for the operation of various attachments and unpressurized flow to tank function**
- **Tilt rotator control**
- **Control of attachments**

Your benefits by HYDAC hydraulic controls for attachments:

- Safe locking by leakage-free poppet valves
- Installation space reduction through the use of mini valves
- High flows by the use of size 20 cartridge valves
- High pressure resistant valve technology up to 350 bar
- Compact manifold solutions by the use of multi-functional valves
- Saving of weight and installation space

Attachments Exchange and Control

Interfaces between machine and attachments differ not only from manufacturer to manufacturer, but also in almost every model. Therefore the suspension of each attachment should be tailored to the particular mobile machine.

Disadvantage of direct suspension

If a bucket or another attachment has to be fixed to the excavator arm the attachment manufacturers have to equip their models with the corresponding suspension. Only then both will fit to each other.

The use of quick couplers

The exchange of attachments can be simplified by the use of quick couplers, which allow various combinations in the interaction of excavators and attachments.

Quick coupler with matching adapters allow free and flexible tool choice and furthermore the rapid exchange between different operations – even if there is up to date no standard established for the interface at the machine arm.

Hydraulic control of attachments

A variety of attachments possesses active hydraulic functions, such as cutters, shears, grapples or rotators. For the control of these devices HYDAC offers different standard and individual control manifold and valve solutions.

The extensive machine expertise of HYDAC and active cooperation in close development partnership allow appropriate solutions for single-acting and bidirectional functions of all standard quick couplers, tilt rotators and attachments.

Local presence worldwide

HYDAC is one of the world's leading suppliers of fluid technology, hydraulics and electronics – with over 8,000 employees worldwide. About 50 foreign companies and more than 500 sales and service partners guarantee efficient local service – wherever you need support.

The width of the product range of HYDAC and our expertise in development, manufacturing, sales and service allow comprehensive concepts – from individual components to the complete system.

Note

The information in this brochure relates to the operating conditions and applications described. For applications and/or operating conditions not described, please contact the relevant technical department.

Subject to technical modifications.

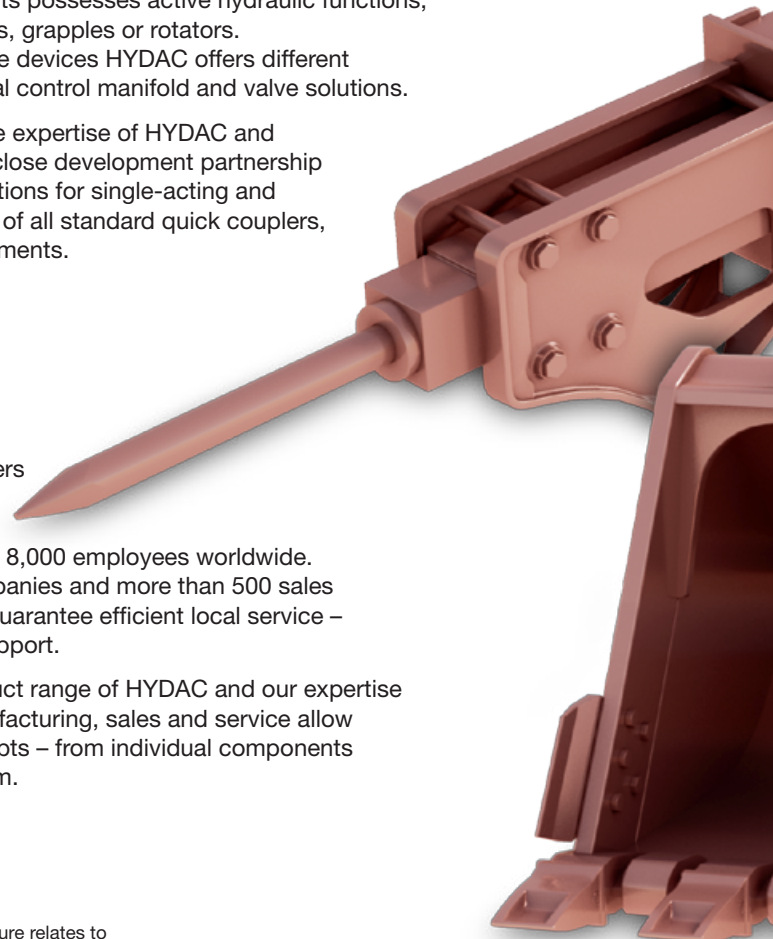



Hydraulic Control Solutions for...

Pressure control of quick couplers



Refinement of quick coupler controls:
Two separate pressure reducing valves are replaced by one proportional pressure reducing valve PDR08PY which additionally to its proportional function switches between two switchpoints (here minimum and maximum set pressure).

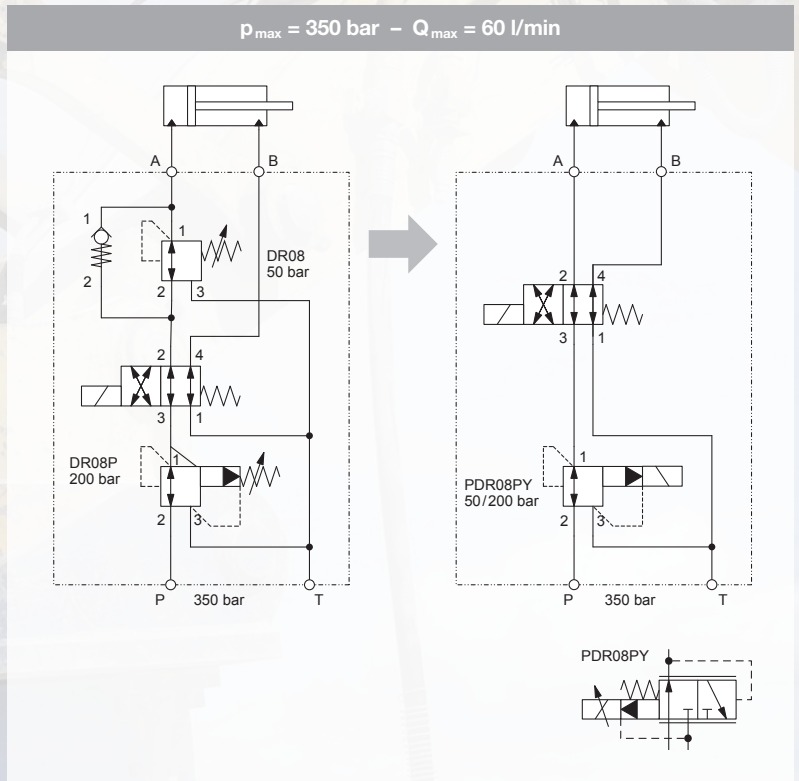

Pressure safeguarding of quick couplers



The electrically switchable pressure relief valve DB10PY ensures the safeguarding of the pressure and the bypass for the quick coupler. It is switchable between unpressurized flow and system pressure. In bypass function there is only a very small Δp created across the valve. By the incorporation of mini valves – here a 4/3-spool and a check valve RV06 – the manifold is very compact. Installation cavities and costs are saved by the combination of several functions in one valve.

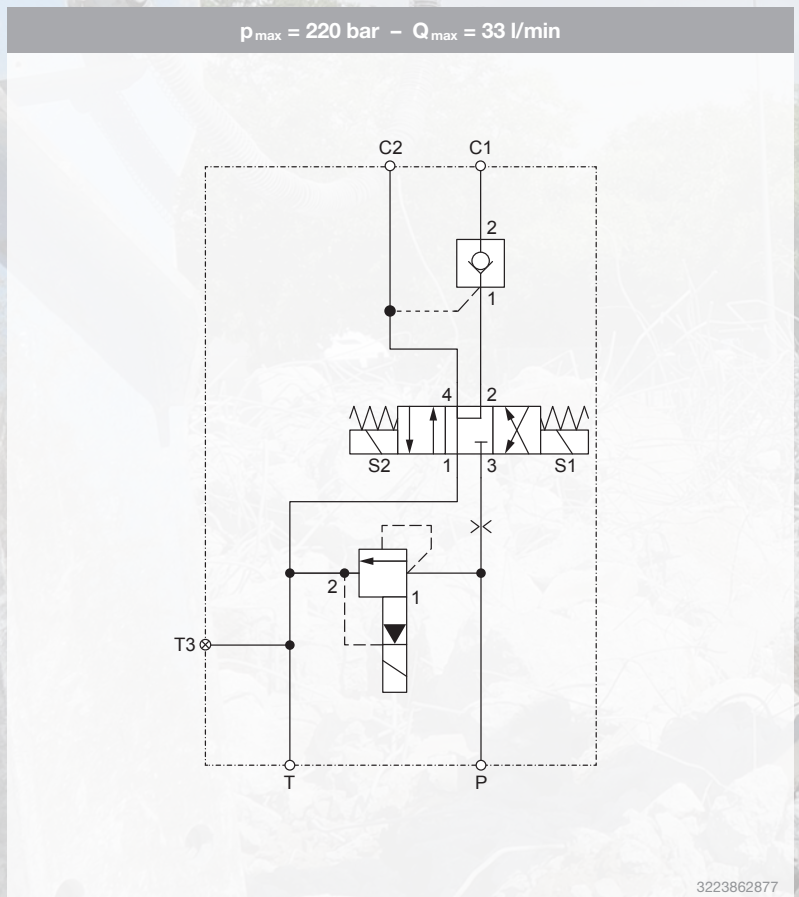

Fully automatic quick coupler with pressure sequence circuit



This manifold ensures on the one hand the locking of attachments and on the other hand the connection of hydraulic ports.
At the end stop of the locking cylinder the pressure increases until the pressure relief valve opens the flow to the coupling cylinders.

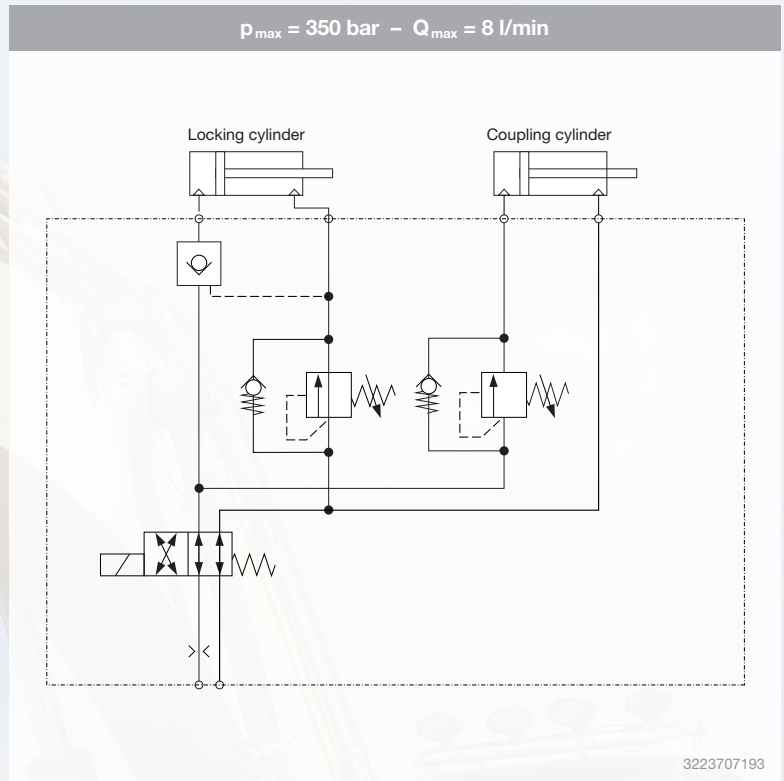

Pressure safeguarding of attachments



Pressure settings for various attachments with simultaneous bypass control to tank. The cleanest solution to supply and safeguard attachments: On the one hand the proportional supply of attachments with the respective required pressure is done via the integrated proportional pressure relief valve PDB16PZ; on the other hand the backflow is directly running through a separate filter to the tank.

This is switched by two 2/2-way poppet valves (bypass valves) and no fluid flows over the main spool valve anymore. This primarily ensures that no backpressure arises at e.g. a hammer, whereupon it reacts sensitive. Also, a possible contamination cannot enter the system, but will be directed over the filter directly into the tank.

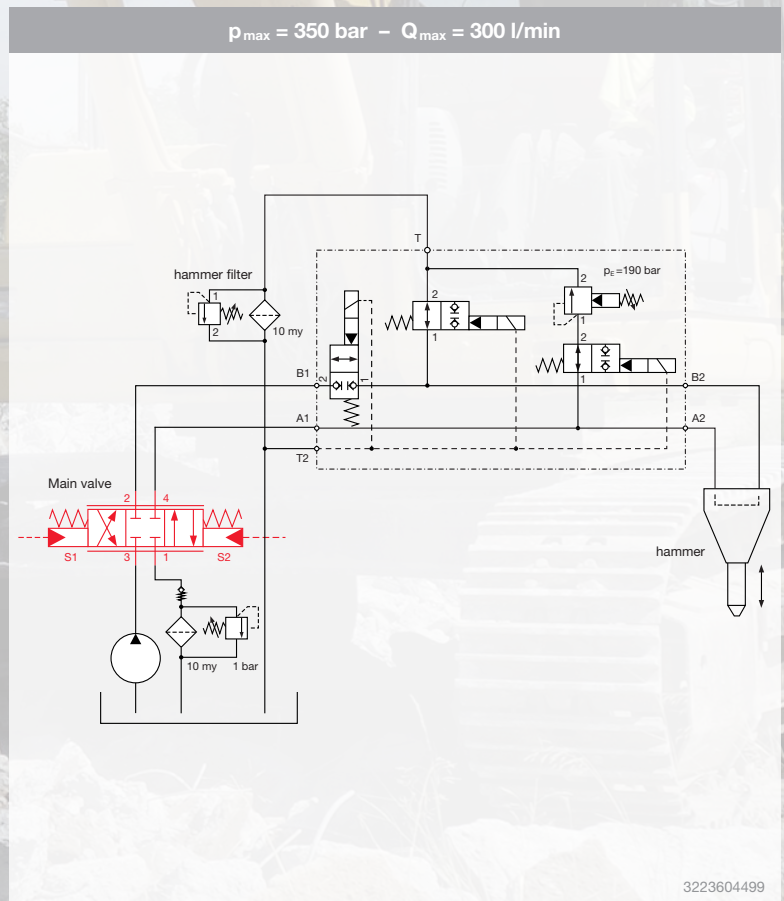

3223604499

Hydraulic Control Solutions for...

Pressure safeguarding of attachments



Manifold for the individual proportional supply of the supplementary circuit with the respective required pressure. The integrated proportional pressure relief valve in fail-safe design reaches its maximum pressure at zero current supply.

The hydraulic supply gets along with only one pressure relief valve for both flow directions since corresponding check valves are integrated before. An integrated bypass valve (2/2 directional solenoid valve) ensures that the backflow is directed loss-free and directly to the tank and only a small amount is flowing over the 4/3-main spool valve. This ensures particularly for sensitive attachments that no back pressure is created and the flow is fastly directed to tank. On the other hand a possible contamination can hardly not access the system.

$p_{\max} = 245 \text{ bar} - Q_{\max} = 230 \text{ l/min}$

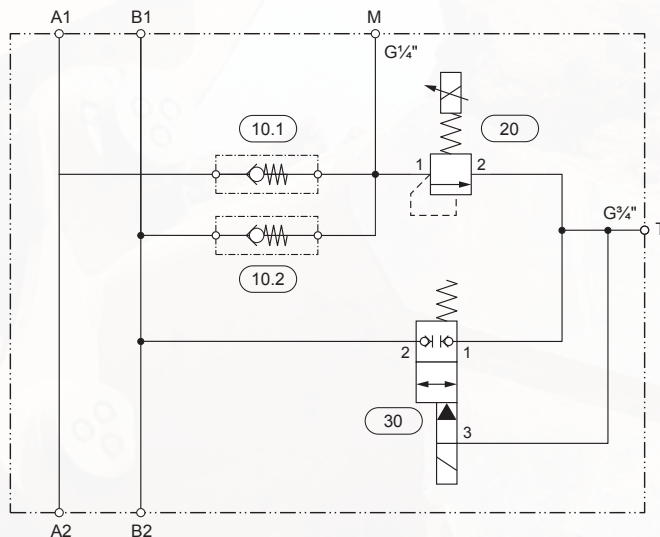

3224062672

Supply and actuation of quick couplers



Actuation, safeguarding and pressure regulation of quick couplers – integrated in one manifold.

By the use of a combination valve type WKDRM08140 three functions in one single valve are realized: 4/2 directional spool valve, 3-way pressure reducing valve and bypass function. This makes the manifold extremely compact and cost effective while preserving full functionality.

$p_{\max} = 350 \text{ bar} - Q_{\max} = 10 \text{ l/min}$

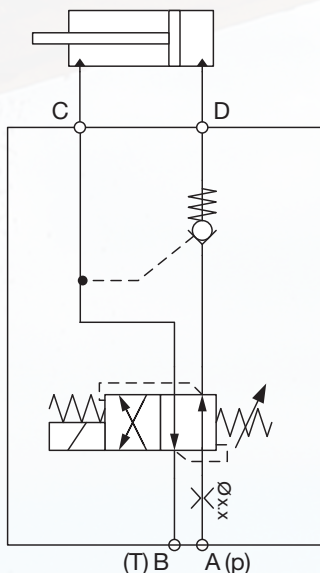

3224128928

Locking and release of attachments



In general the locking and release of attachments is done by two bolts, which are actuated by this manifold. This is realized by the built-in 2/2 directional mini-valve. Installation in 3rd supplementary circuit of the wheel loader. The manifold is mounted space-saving and in protected area by banjo bolt directly at the rocker – therefore it might not be damaged by hazard. The mini-valve only needs small electrical current and switches up to 15 l/min flow and therefore is very energy-efficient.

$p_{max} = 280 \text{ bar} - Q_{max} = 15 \text{ l/min}$

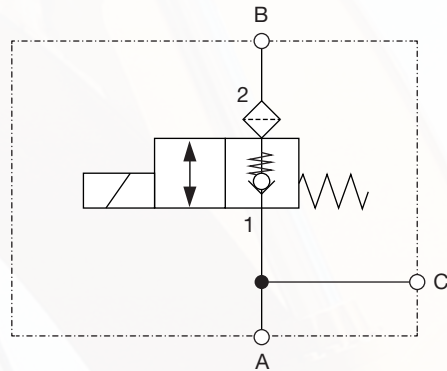

3223655186

Control of quick couplers



Manifold with 4/3 directional spool valve for the direct control of the quick coupling cylinder. Special type of spool valve – by restricted supply and discharge in center position a possible outer leakage will be reduced and the environment protected.

$p_{max} = 210 \text{ bar} - Q_{max} = 23 \text{ l/min}$

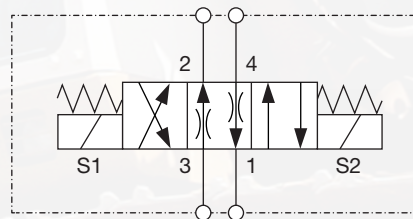

3224078553

Technical Data

Flows	15 up to 300 l/min
Operating pressure	30 up to 350 bar
Fluids	Hydraulic oil according to DIN 51524 Part 1 and 2
Media operating temperature range	-20 °C up to max. +100 °C
Ambient temperature range	-20 °C up to max. +60 °C
Viscosity range	10 – 420 mm ² /s is recommended
Filtration	Max. permitted contamination of the fluid according to ISO 4406 Class 21/19/16
Weight	from 3 up to 13 kg
Electrics and electronics for the control of the solenoids	
Supply voltage	12 V or 24 V DC
Resistance	Coil 40-1836: 1.5 A at 12 V, 0.8 A at 24 V Coil 20-1323: 0.8 A at 12 V, 0.4 A at 24 V
Nominal current at 20 °C	1,050 mA at 12 V DC
Voltage tolerance	±15 % of nominal tension
Switch-on time	100 % ED (continuous duty) up to max. 115 % of nominal voltage at 60 °C ambient temperature
Coil type	Coil...20-1323 for mini-valves Coil...40-1836 for standard valves Coil...50-1836 for standard valves with increased need of force Coil...50-2345 for valves with high force
Electronical control	Power amplifier, e.g. top hat rail mounting, plug type, e.g. type EHCD AM003 with RS232 interface

Valve Solutions for the most different tasks



$p_{max} = 350 \text{ bar} - Q_{max} = 120 \text{ l/min}$

DB10PY

Combination of 2/2 directional spool valve (bypass valve) and pilot operated pressure relief valve. Softshift use with electrical ramp possible (similar proportional valve) for smooth starting and finishing. Manually adjustable maximum pressure. The valve could be actuated between unpressurized flow and system pressure relief and substitutes a separate bypass and pressure relief valve. The result: space, cost and weight savings.

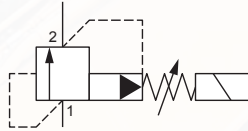

$p_{max} = 420 \text{ bar} - Q_{max} = 300 \text{ l/min}$

PDB16PZ

Proportional pressure relief valve – fail-safe type (zero current = maximal pressure). Designed for high flow-rates and small pressure loss at discharged valve (maximal current supply).

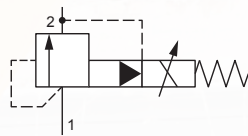

$p_{max} = 350 \text{ bar} - Q_{max} = 15 \text{ l/min}$

WS06ZR

Leakage-free 2/2 directional solenoid poppet valve, pilot operated, reverse flow. Mini-valve type.

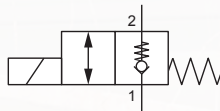

$p_{max} = 350 \text{ bar} - Q_{max} = 60 \text{ l/min}$

PDR08PY

Proportional pressure reducing valve, normally open, with integrated mechanical adjustable minimal- and maximal pressure. Enables herewith the switching between two different system pressures – optional possible as on/off valve.



$p_{max} = 350 \text{ bar} - Q_{max} = 32 \text{ l/min}$

WK10E-81

4/3 directional spool valve with restricted flow in center position. For higher safety in case of hose-break in mobile machines.

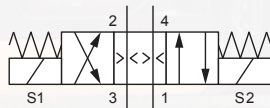

$p_{max} = 160 \text{ bar} - Q_{max} = 10 \text{ l/min}$

WKDRM08140Y

Multifunction valve – replacing 3 single valves: 2/2 directional spool valve with integrated 3-way pressure reducing valve and check function. Offers highest space and cost savings by the use in manifolds.

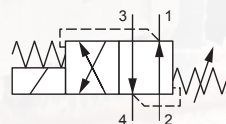

System Intelligence

Electro-hydraulic system solutions as the interface between actuators and sensors

The demands of modern excavators are leading to ever-increasing complexity of control systems. Modern machines require a variety of assistance and control systems wherever simpler operating concepts and a better overview and controllability of the machine functions become necessary.

Electro-hydraulic control technology

From component to intelligent system solution.

HYDAC offers everything from all kinds of hydraulic and electronic components and subsystems to finished functional solutions that can also include the corresponding application software.

See catalogue 18.500 – Control Technology for Mobile Machinery + see brochure 18.000 – Measurement Equipment for Hydraulics and Pneumatics

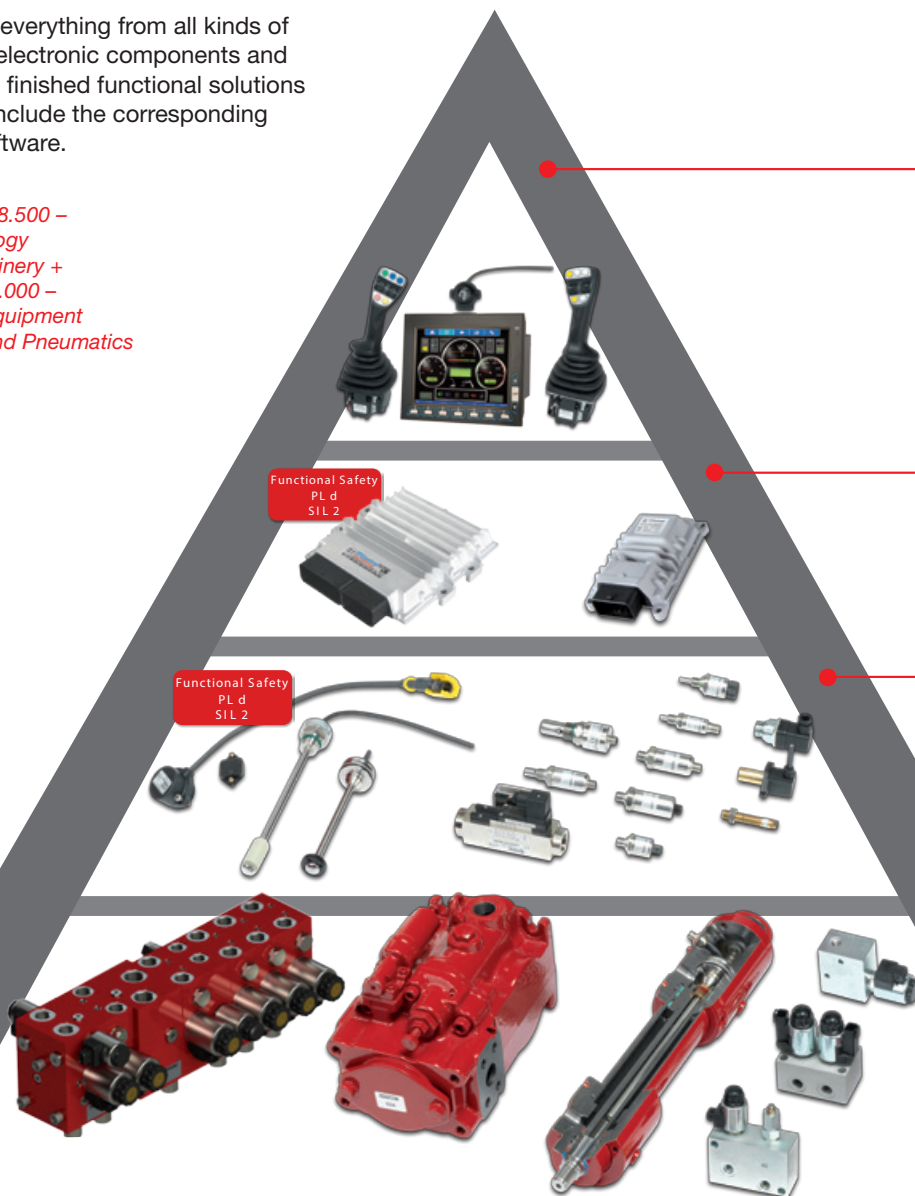



USER LEVEL

- Displays for the most demanding visual requirements
- Peripherals, e.g. joysticks

CONTROL LEVEL

- Controllers in various classes
- I/O expansion modules
- Standard version and versions with increased functional safety are available

SENSOR LEVEL

- Pressure and temperature
- Distance, position, angle, inclination and level
- Drive speed
- Flow and oil level
- Standard version and versions with diagnostics and increased functional safety available

ACTUATOR LEVEL

- Pilot-controlled and direct-acting valves
- Control blocks (monoblock/sandwich)
- Pilot and primary control systems
- Intelligent axles
- Cylinders, pumps and motors

System development

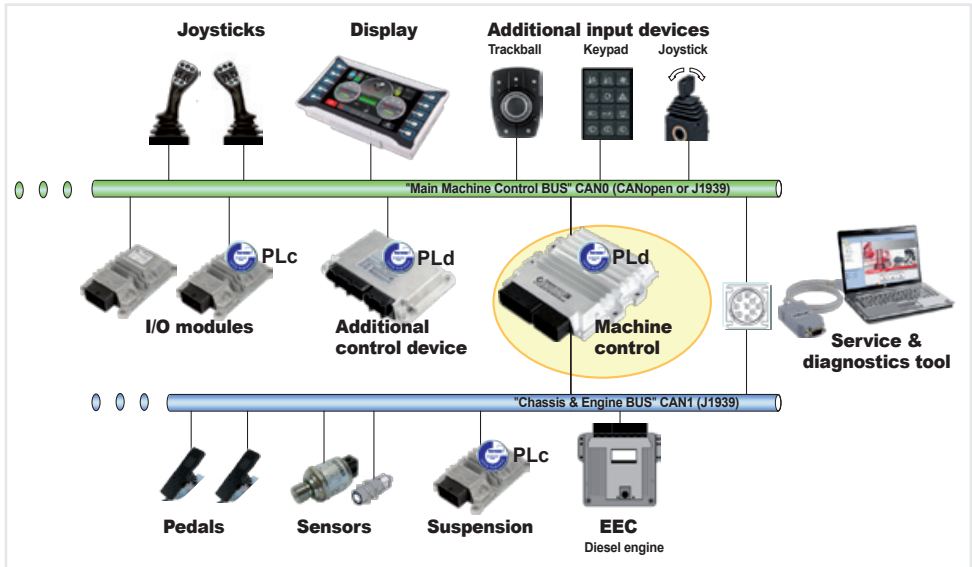

Example of control architecture

Based on the customer's requirements, HYDAC offers support across the spectrum with developing electro-hydraulic control systems for mobile machinery. The scope of development is determined together with the customer according to the task.

Services can include:

- Creating customer-specific application software (according to specification)
- Integrating intelligent subsystems into the customer's machine (e.g. suspension systems, secondary steering systems, fan controls)
- Complete control solutions for mobile machinery (safety functions, electrical/electronic control architecture, application software)

Software development

Depending on the hardware, the following programming languages can be used to program the application software:

- CoDeSys 2.3/3.5/3.5 SIL2
- C
- MATLAB/SIMULINK

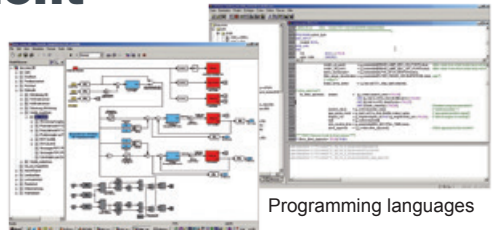

Programming languages

System development support

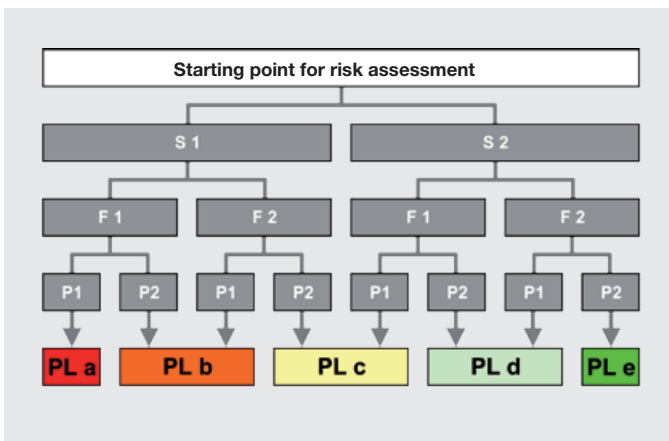

Severity of injury

- S1 Minor, temporary injury
- S2 Severe, irreversible injury including death

Frequency/duration of exposure to hazard

- F1 Rare or brief exposure to hazard
- F2 Frequent to continuous exposure to hazard

Possibility of avoiding the hazard or limiting the damage

- P1 Possible under certain circumstances
- P2 Practically impossible

HYDAC offers extensive consultation and support for customer projects with regard to:

- Hazard and risk (H&R) analysis
- Definition and description of safety functions
- Drafting safe system architectures and user interfaces (HMIs)

“MATCH” development environment

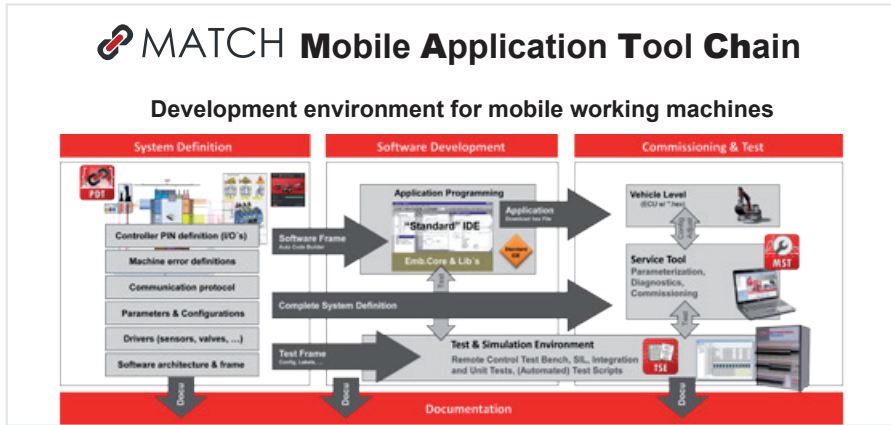

Mobile Application Tool Chain

With the “MATCH” (Mobile Application Tool Chain) development environment, HYDAC offers a tool chain for system-level software development by the customer that is specially suited to the requirements of mobile machinery. “MATCH” supports development from defining the system at the vehicle level and creating the application software to start-up, testing, and documentation.

“MATCH” offers modules for:

- Defining the system at the vehicle level
- Starting up and servicing the machine
- Testing software
- Documentation

Furthermore, an “Embedded Middle Ware” is offered which permits a hardware-independent programming of the application and which contains a multitude of basic functions. A comprehensive selection of library modules (e.g. for sensor and valve drives) is also available for an efficient development of the application software.

Functional safety

“MATCH” can also write application software with increased functional safety according to the following safety standards:

- “SIL 2” to IEC 61508
- “PL d” to EN ISO 13849

Software library

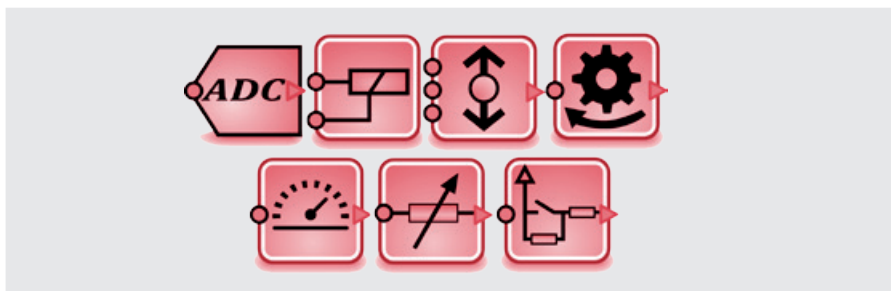

Selection of library modules

In order to make software development significantly easier for the customer, HYDAC offers software libraries with ready-made modules as part of its “MATCH” development environment. The library modules can be configured and parameterised as desired.

Examples of library modules include:

- Sensors
- Switches
- Proportional and switching valves
- Relays, LEDs
- Transfer functions / signal elements

Special error modules can also be used to detect system errors.

Additional Solutions

Perfectly tailored to the HYDAC Technology Platform

Cab-air filter for very fine and nano dust: CabinAirCare

Construction machines must not be used in contaminated areas unless the driver's cab is equipped with filtration and/or compressed air systems to ensure an air supply of sufficient breathing quality.

For tasks such as landfill sealing or encapsulation or land rehabilitation, a CabinAirCare module can be retrofitted to existing vehicles to provide optimum protection for the driver without having to make drastic changes to the existing air-conditioning system or the cab.

For a healthy environment that promotes performance, HYDAC Filter Technology already offers highly effective air filtration systems that can be equipped or retrofitted.

Customer benefits:

- Easy to install and expand (on existing air conditioning or filter systems)
- Sufficient system reserve (fan power, media sizing) for common cabin sizes in construction and agriculture
- Robust and simple construction
- Filters airborne pollutants, including nano-particles and gases



Fine dust filter



HEPA filter



Active carbon filter

► see brochure 7.016.1 – CACR CabinAirCare

Accessories for every sector

For the completion of hydraulic systems

- Standard fittings and ball valves (high pressure)
- Mounting clamps for hydraulic hoses and pipes, cylinders, electrical cables and accumulators
- Tamper-proof inductive proximity switch (high pressure resistance)
- Fluid level sensors
- Temperature switch TSE
- Standard clamp 3015 air/water reservoir clamping bands
- "Test point" connections
- Quick-release couplings
- Special clamps for particle filters

► see catalogue 61.000 – Accessories

Customer benefits:

HYDAC Accessories is your expert for modifications and special solutions at all times, and especially when custom jobs are required because standard parts are unsuitable.

HYDAC's in-house engineering, coupled with our multidisciplinary approach and worldwide know-how, guarantees state-of-the-art technology and rapid development times.

HYDAC Accessories provide the final perfect touch to your machine with a broad range of standard and special components, also available in stainless steel.



Ball valves

Cylinder systems

Our cylinder systems are notable for their versatility and extreme compactness. We offer cylinder drives with integrated valve technology and guarantee optimal operation of your machine, even with increased operational loads:

- Special mobile cylinders for large excavators and mining excavators, with integrated distance measurement system and special coating for the forged piston rod
- Special suspension cylinders and chain-tensioning units
- Outrigger cylinders with relief
- Mast inclination and kinematics cylinders
- Locking and clamping cylinders

The cylinders can also be weight-optimised and they can be supplied with an integrated distance measurement system.

Customer benefits:

Our own Service Center offers you a comprehensive customer service. We support you with the design, assembly, maintenance and commissioning of your system.

We begin working closely with the customer right from the development stage. Because of our knowledge, we can achieve the best cylinder solution for your product, e.g. by using special surface coatings for the piston rod. FE simulations or fatigue strength calculations also come under our Engineering Standard.

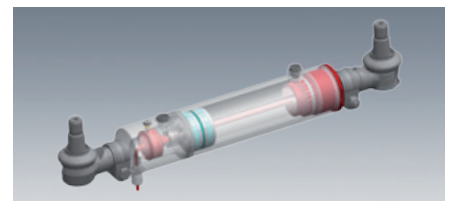

Boom cylinder with integrated position sensor system

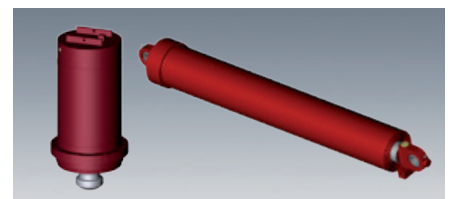

Outrigger cylinder

► see brochure HS-D 10.102 – Cylinders and Cylinder Systems for Mobile Hydraulics

Fluid conditioning systems

To provide flexible servicing on machines, there are convenient mobile units for removing solid particles:

- Portable filtration units
- Mobile filtration units
- Built-in filtration units (offline)

► see catalogue 79.000 – Filter Systems

Customer benefits:

- Clean filling and flushing
- Versatile design – can be used on a variety of systems
- Relief for the in-line filter
- Greater system availability
- Reduction in Life Cycle Cost



Mobile filtration systems

FluidCareCenter

We get involved in the process early on. With our clean room in the FluidCareCenter, we promise you exceptional cleanliness, from the component to the system: Technical Cleanliness is becoming ever more important in mobile hydraulics. Phrases such as “reduction and prevention of production-stage breakdowns” and the difficulty of longer warranty periods are driving up the demands for component cleanliness.

Customer benefits:

- By understanding the relevant cleanliness data of your components, you will be a step ahead of your competitors.
- A laboratory approved and recommended by well-known automotive suppliers
- Many years' experience in the area of technical cleanliness owing to active collaboration on VDA Volume 19 and ISO 16232
- Analysis with the help of extraction units developed at HYDAC
- High-quality analysis equipment
- Ongoing continual development of equipment and processes to meet the increasing requirements and needs of customers



FluidCareCenter

► see brochure 7.128 – FluidCareCenter

Condition monitoring and service

Constantly growing demands for operational availability, reduction in downtime, detailed load and service management (economic viability, wear, service, warranty) require innovative and comprehensive monitoring, service and control concepts. A variety of sensors provides the ideal basis for the development of such integrated system solutions.

- Oil condition, e.g. time deterioration or presence of contaminating fluids can be determined via the saturation level, temperature, change in electrical conductivity, change in dielectric constant (HYDACLAB®)
- Saturation level (AS)
- Particle contamination (CS)
- Pressure (HDA)
- Flow rate (EVS)
- Fluid level (ENS, HNT)

In combination with portable measuring instruments (HMG series), this data can be recorded and analysed to supplement the machine electronics (service).

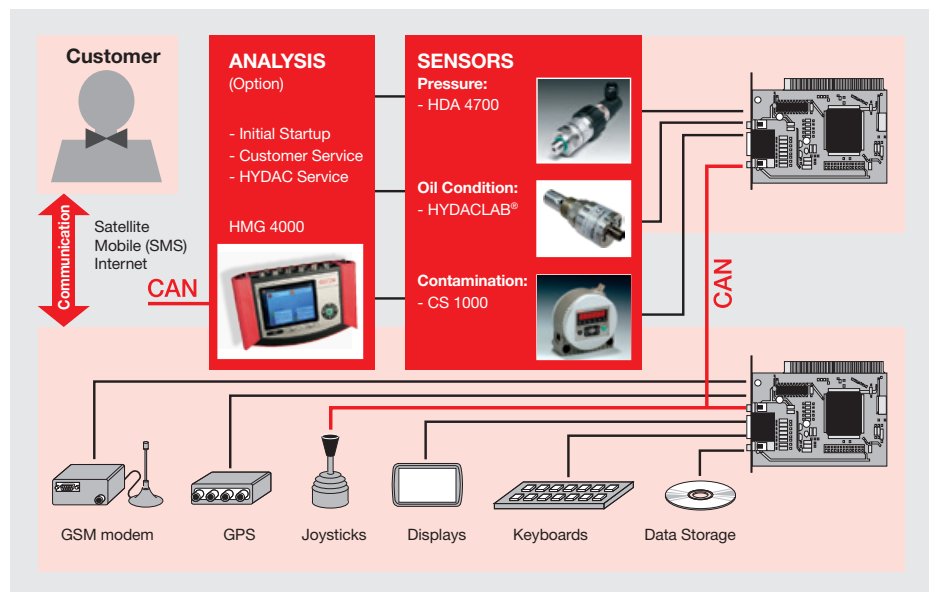

► see brochure 10.122 – Condition Monitoring for Efficient Life Cycle Cost Management
see brochure 18.000 – Measurement Equipment for Hydraulics and Pneumatics



Accumulator Technology 30,000



Filter Technology 70,000



Process Technology 77,000



Filter Systems 79,000



Compact Hydraulics 59,000



Accessories 61,000





Electronics 180,000



Cooling Systems 57,000

Global Presence. Local Expertise. www.hydac.com



-  HYDAC Headquarters
-  HYDAC Companies
-  HYDAC Sales and Service Partners

HYDAC

INTERNATIONAL

Head Office
HYDAC INTERNATIONAL
GMBH

Industriegebiet
66280 Sulzbach/Saar
Germany

Tel.: +49 6897 509-01
Fax: +49 6897 509-577

E-mail: info@hydac.com
Internet: www.hydac.com