

Applications

Frontloaders

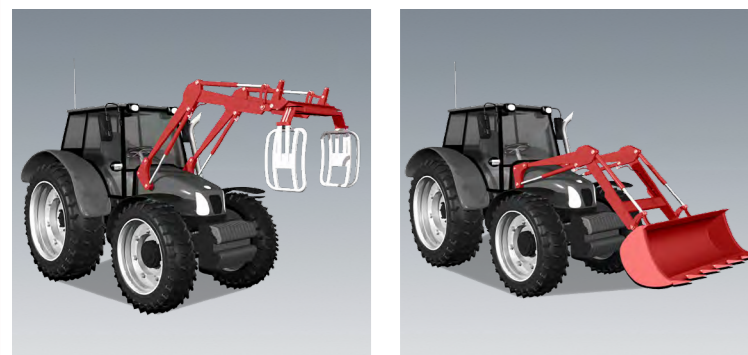

- Very low leakage**
Design experience and manufacturing
- Adapted to available space**
Pioneers in compact design
- Environmental requirements**
A robust monoblock valve
- System requirements**
Adjusted to the vehicle

Cranes / Forestry Cranes



- Controllability**
Spool design
- Safety regulations**
Overload protection, load holding valves
- Low power losses**
Smart system solutions
- Safety**
Protection against incorrect connection
- Ergonomics**
Design and weight
- Ergonomically designed for ease of use**
Manual triple axis hand levers

Tipplers / HGV Superstructures



- Low pressure drops**
Fast lowering
- Multiple functions**
Quick and simple thanks to combination valves
- Customized**
Combination of various sizes
- Monitoring of the lowering speed**
adapted and manually adjustable spools

Wheelloaders / Excavators



- Customized**
Developed section by section, adapted inlet and outlet sections
- Limited space in cabin**
Adapted hand levers
- Lowering speed control**
Adapted spools

Competence with a Firm Foundation.



HYDAC and Nordhydraulic together can provide highly individual solutions, tailored to customer requirement, in addition to standard products for mobile systems.

A team of technical product specialists has been appointed to pool the know-how and experience of both companies in mobile applications. We can, therefore, support your projects with extensive engineering services, joint product development and testing.

With more than 8,000 employees worldwide, HYDAC is one of the leading suppliers of fluid technology, hydraulic and electronic equipment.

Our wide range of products, combined with our expertise in development, manufacturing, sales and service enables industry worldwide to overcome the most diverse problems.

Our quality and environment certification to ISO 9001/2000 and ISO 14001 denote first class quality and responsible management of our resources.

Global yet Local.

With over 45 overseas subsidiaries and more than 500 distributors and service partners, HYDAC is your reliable partner worldwide.

System Solutions. One Supplier. One Contact.

Wherever you need us, we are there to help you find the most effective solution – for every application, from components to a complete system.



Nordhydraulic Kramators SE



HYDAC Denmark



HYDAC China

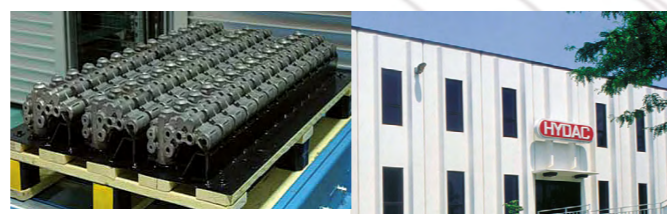

HYDAC USA



HYDAC Italy



HYDAC France



HYDAC Sulzbach/Saar Plant 8

Global Presence. Local Expertise.



- HYDAC Headquarters
- Companies
- Distributors and Service Partners
- Nordhydraulic Facilities



Head Office
HYDAC INTERNATIONAL GMBH

Industriegebiet
66380 Sulzbach/Saar
Germany

Phone: +49 6897 509-01
Fax: +49 6897 509-577

E-mail:
mobilevalves@hydac.com

Internet:
www.hydac.com

Note

The information in this brochure relates to the operating conditions and applications described.

For applications and operating conditions not described, please contact the relevant technical department.

Subject to technical modifications.

HYDAC INTERNATIONAL

Mobile Valves

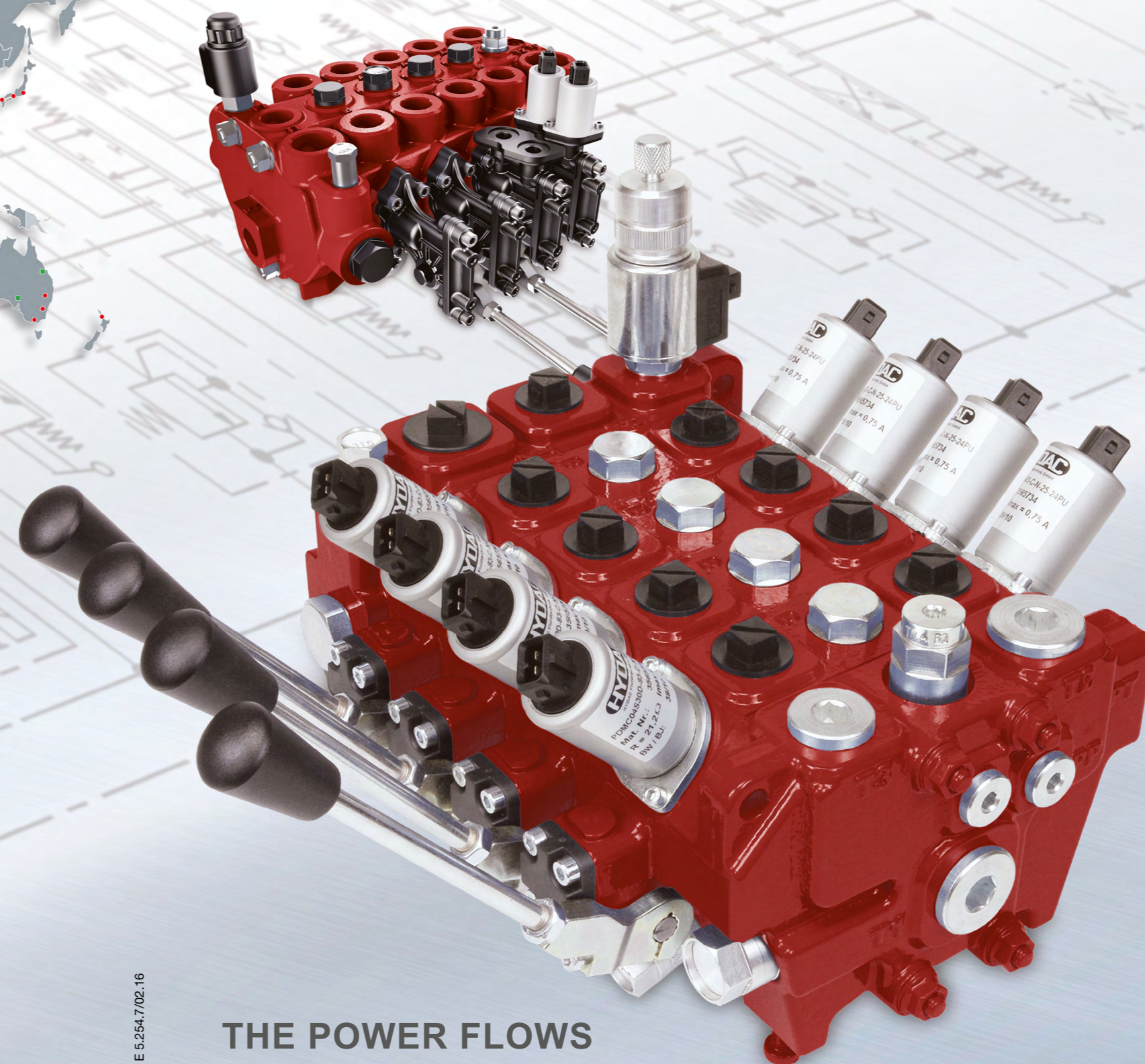

THE POWER FLOWS

HYDAC

Your Partner for Mobile Valves.

Results based on cooperation.

Integrated into the HYDAC Group the specialized products and systems from Nordhydraulic – a globally represented manufacturer of mobile valves – can be offered through HYDAC's strong sales organization.

Our mobile valves fulfill the requirements of truck loading cranes, excavators, skip loaders / demountable bodies, wheel loaders, forestry equipment and other specialized machinery.

The valves are characterized by highly advanced design solutions, including customized spools. Our objective is to optimize the controllability and performance of the machine.

The HYDAC network of top-quality suppliers and partners, in combination with our own foundry and our high performance production provides us with the capacity to serve and satisfy all customers, regardless of size and volumes.

Cutting-edge application expertise is constantly on hand and you, our customer, can always rely on receiving the very best.

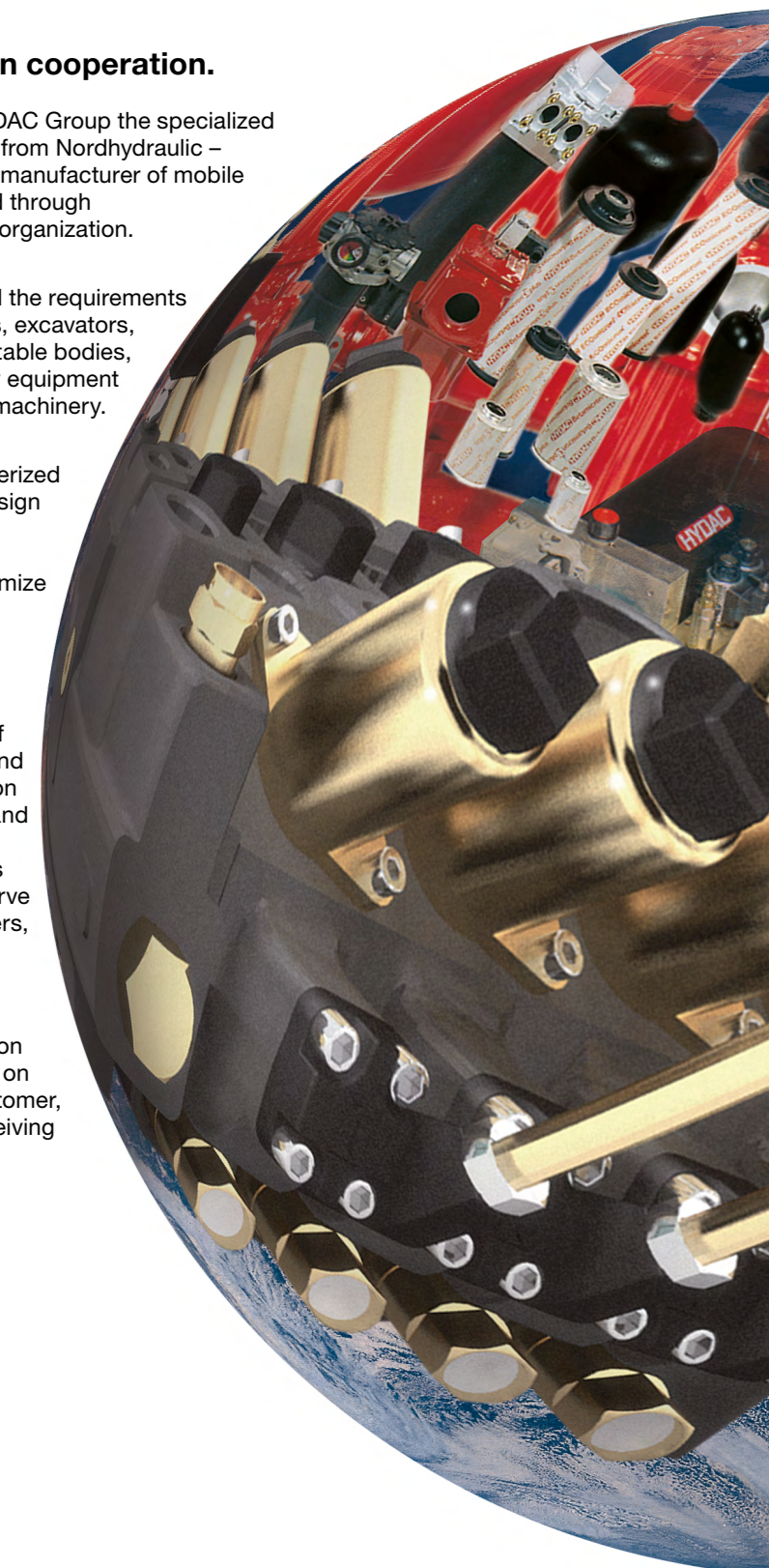
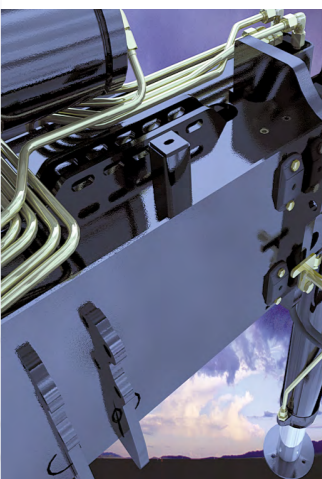

Universal Standard Directional Control Valves

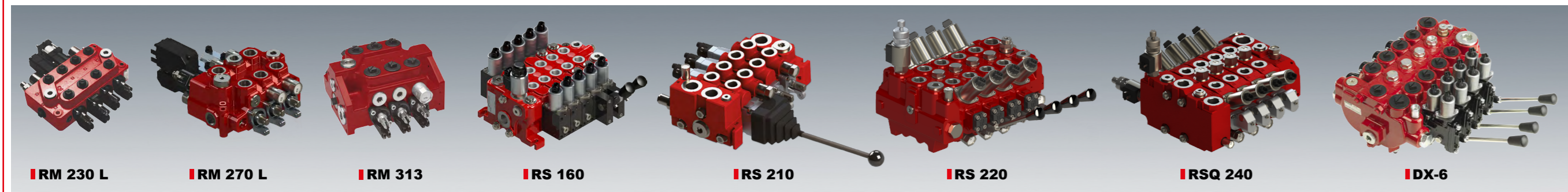

Type	Max. flow* l/min	Operating pressure* bar	No. of sections	Constant Pump	Variable Displacement Pump	Electric. Flow Unloading	Q-Function Flow Control	Hydr. Spool Kickout	Control Options							Electr. Spool Position Indicator (PLd; SIL 2)	Workport Connections BSP**
									Cable	Manual	Pneum.	Electr. Pneum.	Hydr. Prop.	Electro. Hydr. Prop./ ON / OFF	CAN-BUS Stepper Motor		
Monoblock Directional Control Valves																	
RM 230 L	70	210	1-4	•				•	•	•	•	•	•	•	•	•	1/2"
RM 270 L	120	210	1-4 and 6	•				•	•	•	•	•	•	•	•	•	3/4"
RM 313	120	225	3	•				•	•	•	•	•	•	•	•	•	3/4"
Sectional Directional Control Valves																	
RS 160	60	250	1-10	•	•	•	•	•	•	•	•	•	•	•	•	•	3/8"
RS 210	70	300	1-10	•	•	•	•	•	•	•	•	•	•	•	•	•	1/2"
RS 220	80	300	1-10	•	•	•	•	•	•	•	•	•	•	•	•	•	1/2"
RSQ 240	100	350	1-10	•	•	•	•	•	•	•	•	•	•	•	•	•	1/2"
DX-6	140	350	1-10	•	•	•	•	•	•	•	•	•	•	•	•	•	3/4"

Universal Load-Sensing Directional Control Valves

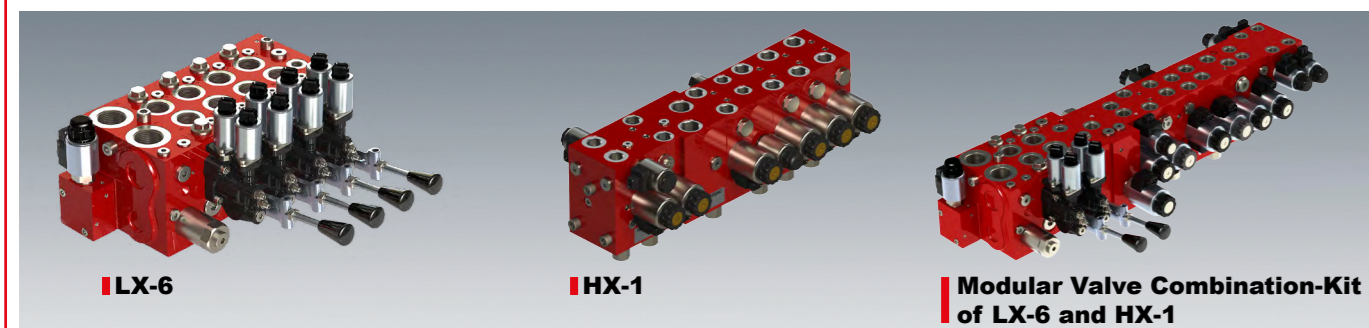

Type	Max. flow* l/min	Operating pressure* bar	No. of sections	Constant Pump	Variable Displacement Pump	Electric. Flow Unloading	Load-Sensing (LS)	Pre-Compensated	Control Options							Electr. Spool Position Indicator (PLd; SIL 2)	Workport Connections BSP**	
									Cable	Manual	Pneum.	Electr. Pneum.	Hydr. Prop.	Electro. Hydr. Prop./ ON / OFF	CAN-BUS Stepper Motor			
LX-6	180	350	1-10	•	•	•	•	•	•	•	•	•	•	•	•	•	•	3/4"
HX-1	120 35 (prop)	250	1-10	•	•	•	•	•	•	•	•	•	•	•	•	•	•	3/8"

• = available • = available upon request
 * Higher values are possible, depending on application and configuration. For applications with data that exceed data stated above, please contact for consideration.
 ** DIN EN ISO 1179-2. Other port threads available upon request.

Frontloader Directional Control Valves



Type	Max. flow* l/min	Operating pressure* bar	No. of sections	Constant Pump	Variable Displacement Pump	Load-Sensing (LS)	Pre-Compensated	Control Options			Workport Connections BSP**
								Cable	Hydr. Prop.	Electro. Hydr. Prop./ ON / OFF	
Standard											
RMX 202	90	300	2	•	•	•		•	•	•	1/2"
RMB 202	90	300	2	•	•			•			1/2"

Standard Selector Valves

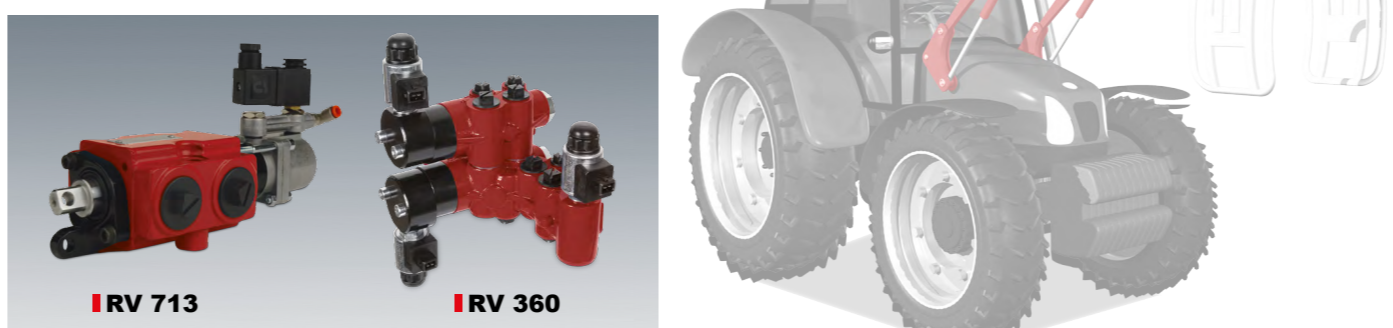

Type	Max. flow* l/min	Operating pressure* bar	No. of sections	Control Options				Workport Connections BSP**
				Pneum.	Electr. Pneum.	Electro. Hydr. Prop./ ON / OFF		
Standard 4/3 Way								
RV 713	160	250	1	•	•			3/4"
Front-Loader 6/2 Way (incl. Front-Loader Dampening)								
RV 360	60	300	1-2			•		3/8"-1/2"

• = available • = available upon request
 * Higher values are possible, depending on application and configuration. For applications with data that exceed data stated above, please contact for consideration.
 ** DIN EN ISO 1179-2. Other port threads available upon request.

Load Holding and Counter Balance Valves

SBVE-, RS series



System modules for various flow rates and control ratios.

Control Modules

Pilot Control Blocks

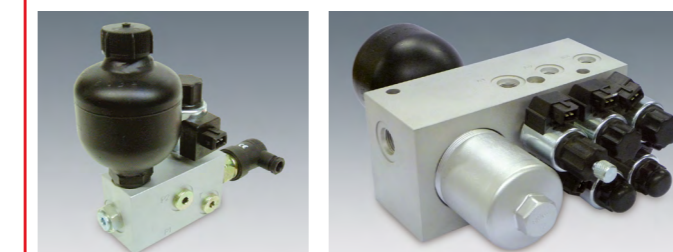

Control blocks for different applications, in different combinations, integration of pressure accumulators and filters possible.

Remote Controls for Valves

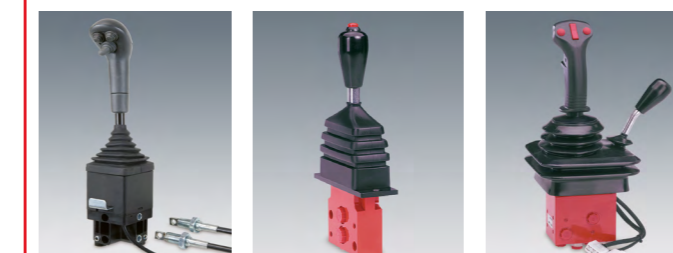

Wide range of remote controls available in single to triple axis. Joysticks / hand levers with different electrical function transmitters available according to customer requirement.

On request, HYDAC can offer a wide variety of customized system solutions also including sensors and electronic controls according to specific application requirements and customer needs.

System Electronics

Electronic Remote Controls



Electronic operating elements available with integrated or external keypad or integrated display.

Radio Remote Controls



Complete remote control systems for proportional operation in different applications.

Displays

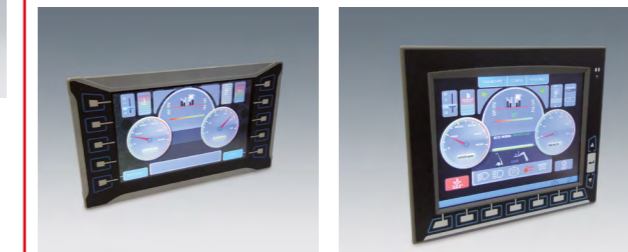

Displays for visualisation solutions available in different sizes and models.

Electronic Control Equipment

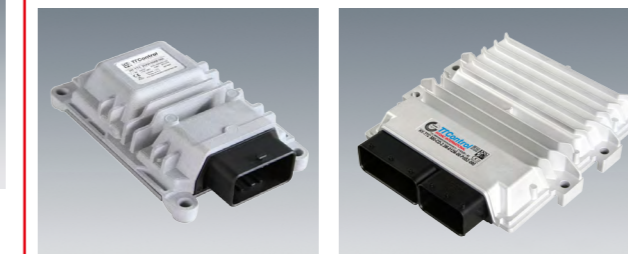

From simple to high-end controls for complex and safety-relevant applications (SIL 2-3).

Sensors



Sensors for enhanced safety requirements (e.g. PLd, SIL 2)

Pressure sensors

Solutions for Electro-Hydraulic Proportional Control

Smart Frontloader Control Package

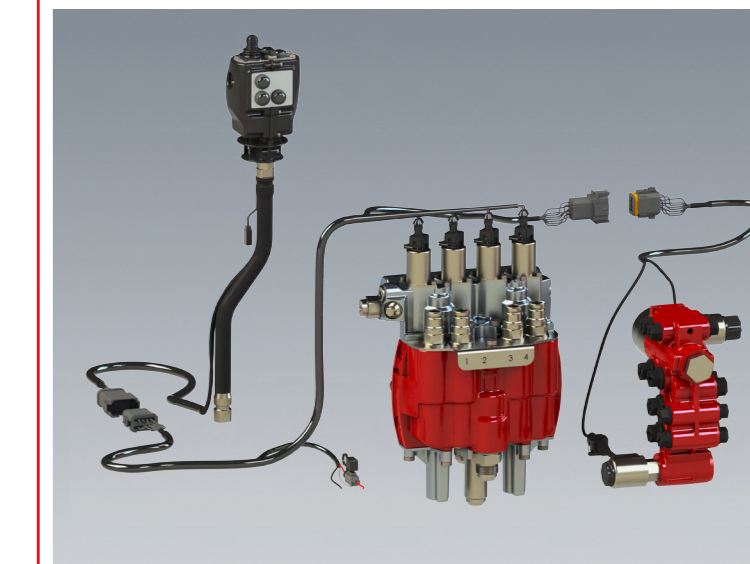

Package consisting of a PWM joystick controller, electro-hydraulic frontloader valve, selector valve with integrated frontloader suspension and harness.

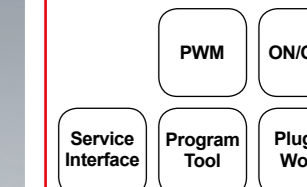

Smart Universal Control Package

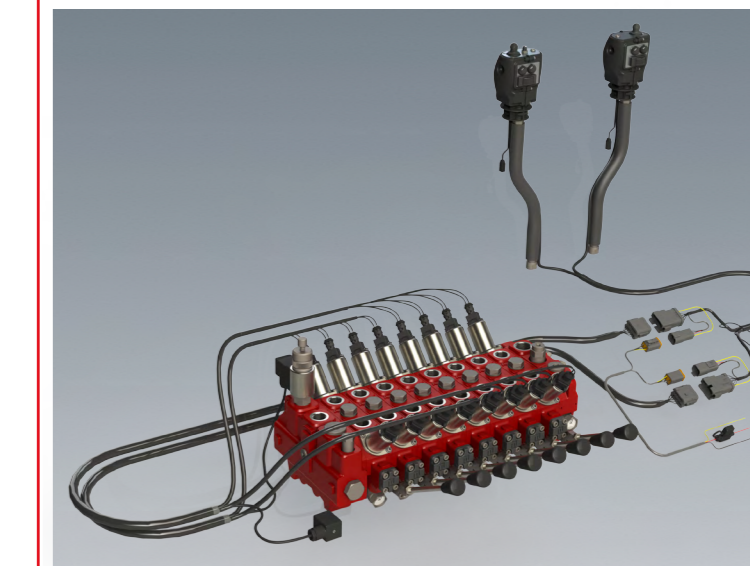

Package consisting of two PWM joystick controllers, electro-hydraulic directional control valve, and harness.

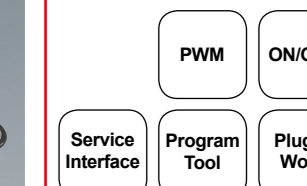

Smart^{PLUS} Universal Control Package

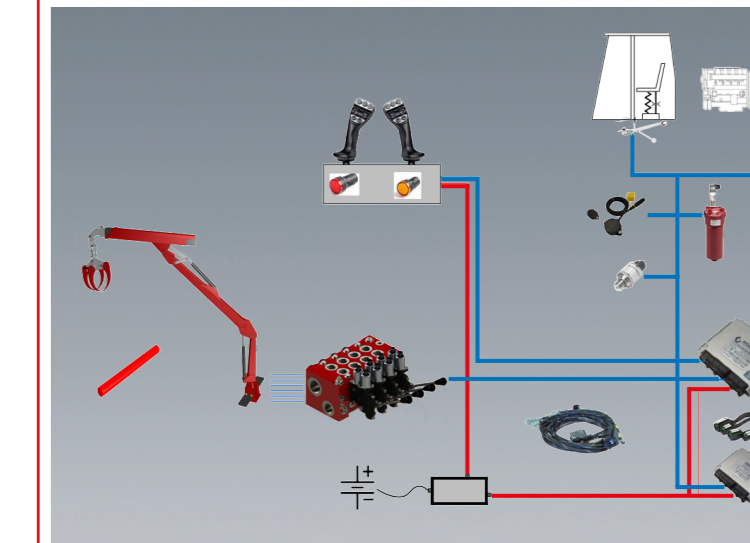

Package consisting of two electronic joysticks, electro-hydraulic directional control valve, sensors, electronic controller and harness.

