

HYDAC

INTERNATIONAL

**Components and
Systems for the
Automotive Industry**

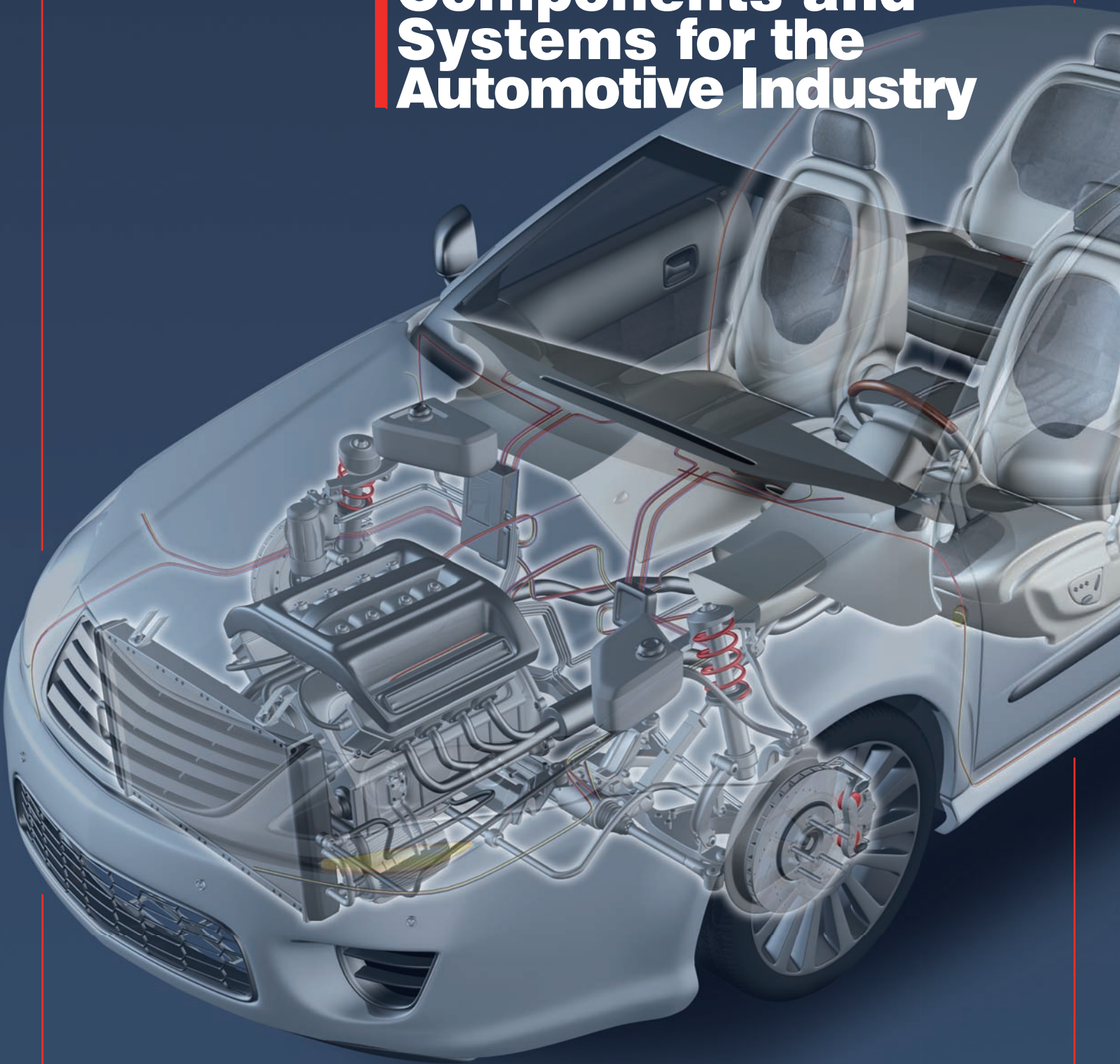



The Professional Partner for the Automotive Industry

With over 6,000 staff worldwide, HYDAC is one of the leading companies in fluid technology, hydraulics and electronics and has many years experience in the automotive industry.

- 1990: Solenoids and filters for Active Rear-Axle Kinematics in top range car
- 1991: Switching solenoids for camshaft phasing
- 1992: Diaphragm accumulator for automatic clutch system
- 1994: Diaphragm accumulator in the rear axle steering system
- 1996: Switching solenoid for truck engine braking system
- 1997: Proportional solenoid for camshaft phasing
- 1998: Diaphragm accumulator for automatic gear shift system
- 2001: Valve / sensor block and filter for active roll stabilization in top range car
- 2002: Mounting clamps for gas tanks
- 2003: Piston accumulator and solenoid valve for camshaft phasing
- 2006: Valve / sensor block and filter for active roll stabilization in SUV
- 2007: Switching solenoid for crash active head restraints
- 2008: Valve / sensor block and filter for active roll stabilization in top range vehicles
- 2009: Valve / sensor block and filter for active roll stabilization in sports car
- 2010: On/off valve for energy efficient pump drive

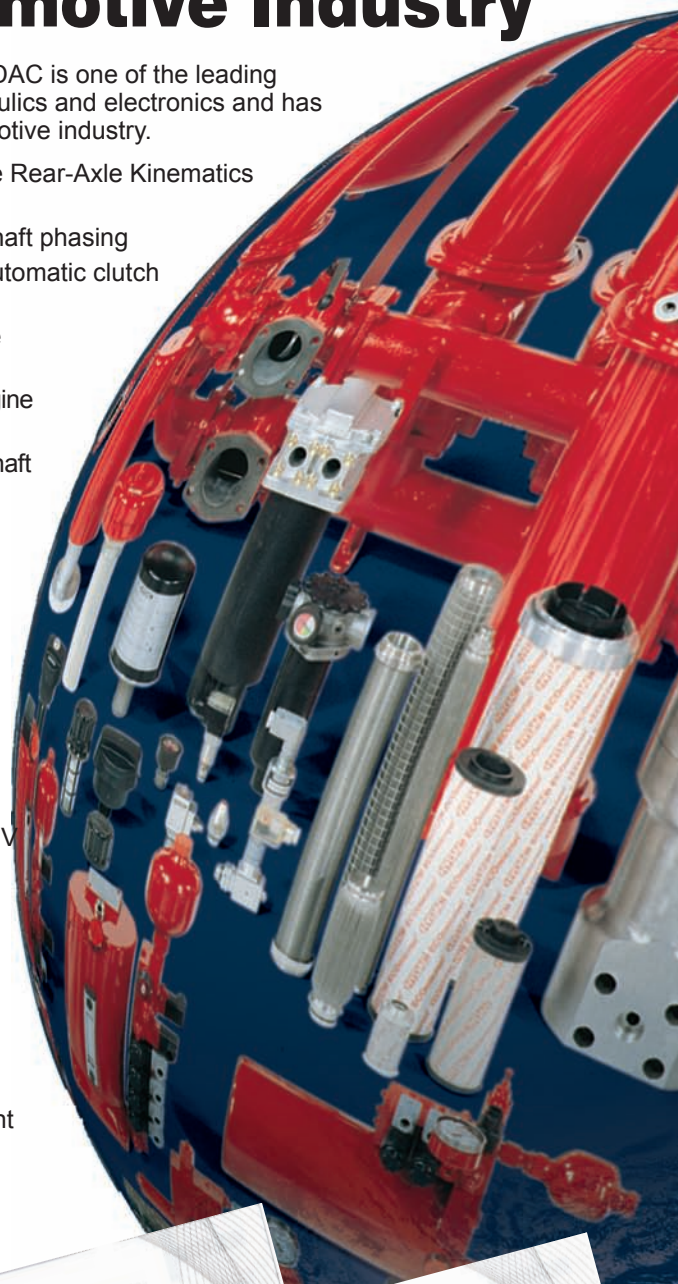

HYDAC Germany



HYDAC USA



HYDAC China



HYDAC Korea



HYDAC India



HYDAC Slovakia



HYDAC Italy

Global and yet local

With over 45 overseas companies, and more than 500 sales and service partners, HYDAC is your reliable partner worldwide.

Worldwide specifications and approvals

Our quality certification to ISO 9001 and ISO 16949 denote first class quality and responsible management of our resources.



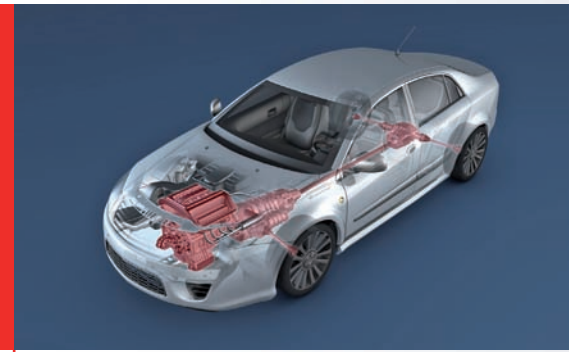

Engine and transmission

- Solenoids and valves for camshaft phasing
 - Good dynamics
 - Improved controllability
 - High level of function integration
- Hydraulic accumulators for energy storage and supply for adjustment and switching processes
- Hydraulic filters for high level of fluid cleanliness for clutch, transmission and engine hydraulics

Solenoids/solenoid valves

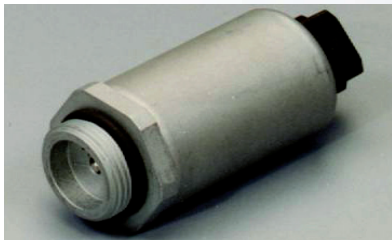

Proportional and ON/Off type.
Various electrical connections available.

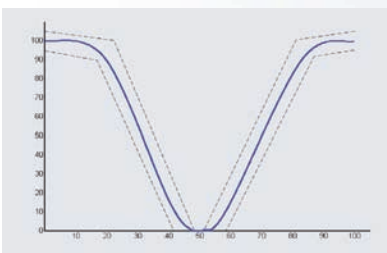

Good controllability and high flow rate



Transmission



Engine

Hydraulic accumulators

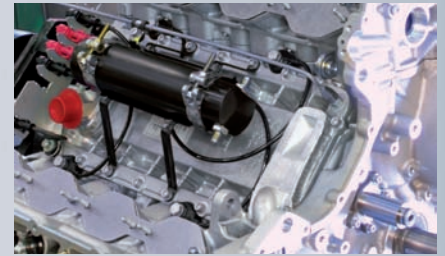

Piston accumulator for camshaft phasing



Lightweight diaphragm accumulator for energy storage in the automatic gear shift system

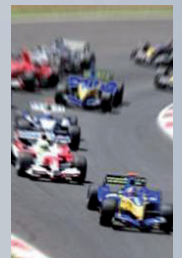

Lightweight diaphragm accumulators in carbon fibre composite construction for the engine hydraulics in Formula 1



Spring accumulators



Metal bellows accumulator

Hydraulic filters

(synthetic, glass or metal fibre)



Engine hydraulics



Dual clutch transmission



Clutch and braking systems



Automatic transmission

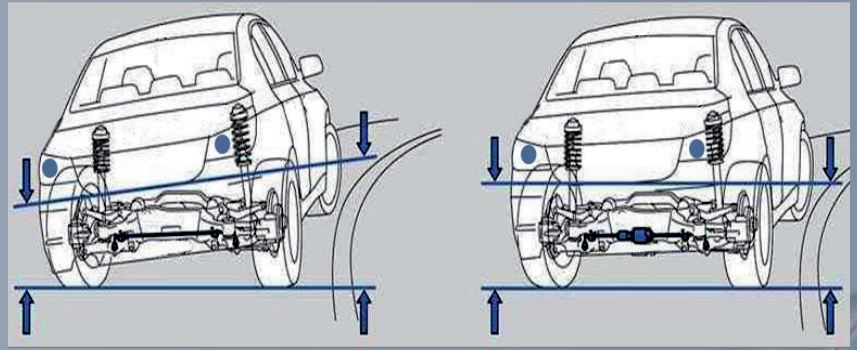
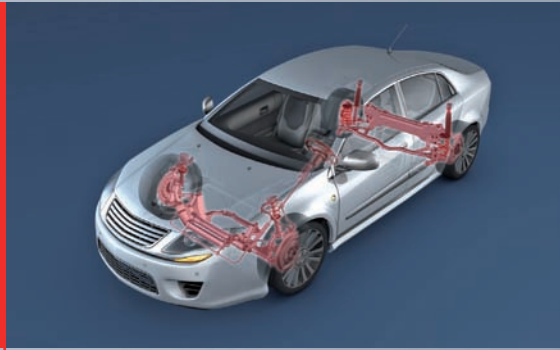

Function principle of active roll stabilization

Chassis

Active roll stabilization and steering

Electro-hydraulic systems for active roll stabilization.

- Good dynamics
- Improved controllability
- High level of function integration

Hydraulic filters in steering and suspension systems

- High rate of contamination retention
- High contamination retention capacity
- Filter mesh pack in glass fibre or synthetic fibre
- Plastic housing
- Integrated bypass valve
- Flow rate up to 25 l/min



Solenoid actuators for crash-active roll-over protection.

- Switching time: < 2 ms
- Ambient temperature: -30 to 90 °C
- Weight: 60 g
- High level of corrosion resistance.





Electro-hydraulic systems for active roll stabilization for top range car



Electro-hydraulic systems for active roll stabilization for sports car



Electro-hydraulic systems for active roll stabilization for SUV



Electro-hydraulic systems for active roll stabilization for SUV



On/off valve for energy efficient pump operation.
10 million switching cycles.



Safety

Fast switching solenoid actuators with low energy requirement for activation via airbag control unit

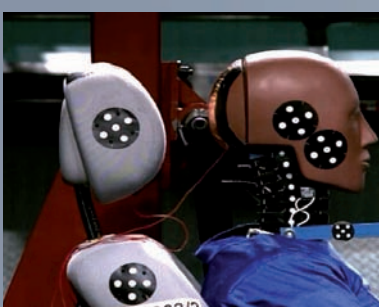

Crash-active head restraints



Solenoid actuators for crash active systems.



Pedestrian protection:
Solenoid low energy actuator for crash active bonnet/hood release
- Switching time: < 2 ms.
- Ambient temperature: -30 to 120 °C
- Weight: 140 g



Environment

Emission reduction

Energy efficiency

HYBRID Technology

- Mounting technology and shut-off valves for gas tanks (CNG/LPG)
- Filter elements and valves for SCR technology
- Dieselfiltration HYDC Diesel PreCare
- Lightweight hydraulic accumulators for hybrid applications

Hydraulic filters



- Deep-bed filter element for SCR technology
- High contamination retention rate and contamination retention capacity due to innovative multi-layer filter media structure
- High strength and durable polymer fibre matrix due to thermoplastic bonding of the fibre structure
- Structural weak points eliminated (e.g. no seam)
- Low pressure drop
- Compact design

Dieselfiltration



- **Manual water discharge**
(BestCost Design)
The conventional, operator-dependent solution.
- **Fully automatic discharge**
Plug & Play (HighTech design)
The innovative solution for fully automatic dewatering, independent of the operator, even during suction side operating.
- 2-stage water separation
- Suction side pre-filter
- Protects all pumps and components in the fuel system from water and contamination

Mounting technology / valves



TÜV certified, patented mounting clamps with quick release fastenings.



CNG shut-off valve

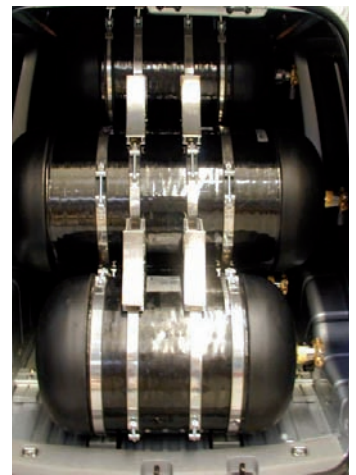

Solenoid for tank vent valve

Hydraulic accumulators

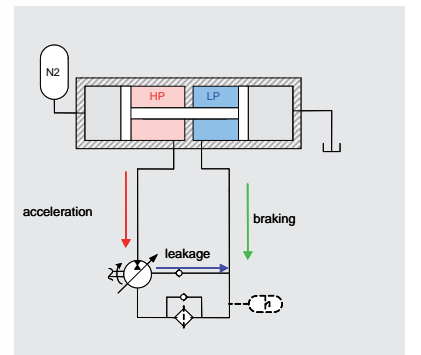
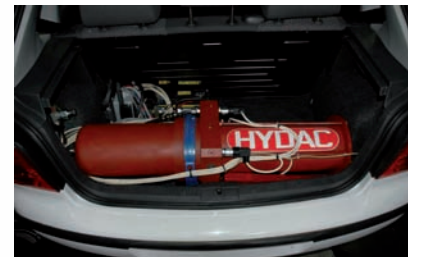

Hydraulic hybrid retro-fit solutions.
Double piston accumulator up to 350 bar.



Development expertise - worldwide

Advice, development support,
system responsibility and expertise

If required, HYDAC will support the customer throughout the product development cycle, from design and simulation up until the product is ready to go into production.

Development tools

MATLAB/SIMULINK

AMESim

ANSYS

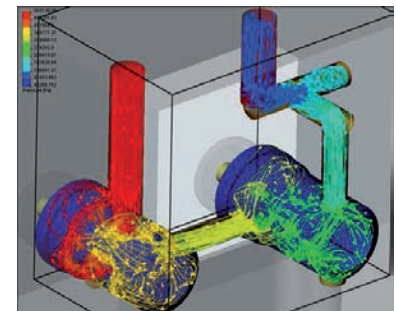
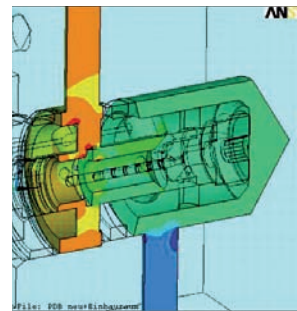
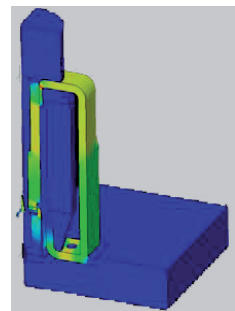
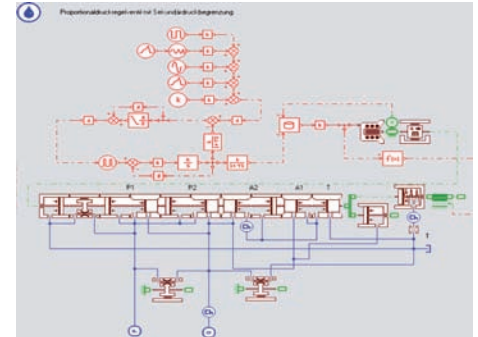
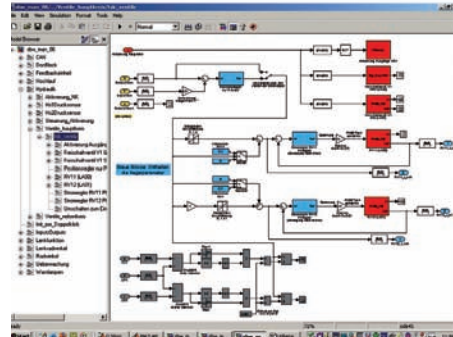

Prototype construction / Laboratory

HYDAC is an innovative development partner and a series production supplier for the automotive industry, providing:

- in-house prototype construction
- individual function and service life test rigs

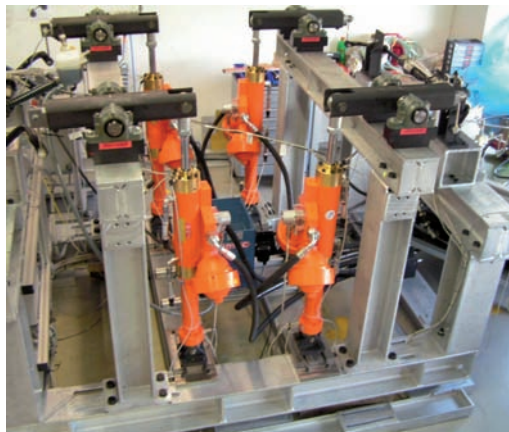

Global presence. Local expertise. www.hydac.com



- HYDAC Headquarters
- HYDAC Companies
- HYDAC Distributors and Service Partners

HYDAC

INTERNATIONAL

HYDAC International
GMBH

Industriegebiet
66280 Sulzbach/Saar
Germany

Telephone:
+49 6897 509-01
Fax:
+49 6897 509-577

E-Mail: info@hydac.com
Internet: www.hydac.com

Cat.: Accumulators E 30.000

Catalogue: Fluid Filters E 70.000

Cat.: Process Technology E 77.000

Brochure: Filter Systems DEF 7.929

Br.: Compact Hydraulics DEF 5.300

Catalogue: Accessories E 61.000

Catalogue: Electronics E 180.000

Broch.: Cooling Systems DEF 5.700