

HYDAC

INTERNATIONAL

**Components
and Systems for
Road Construction
Machinery**

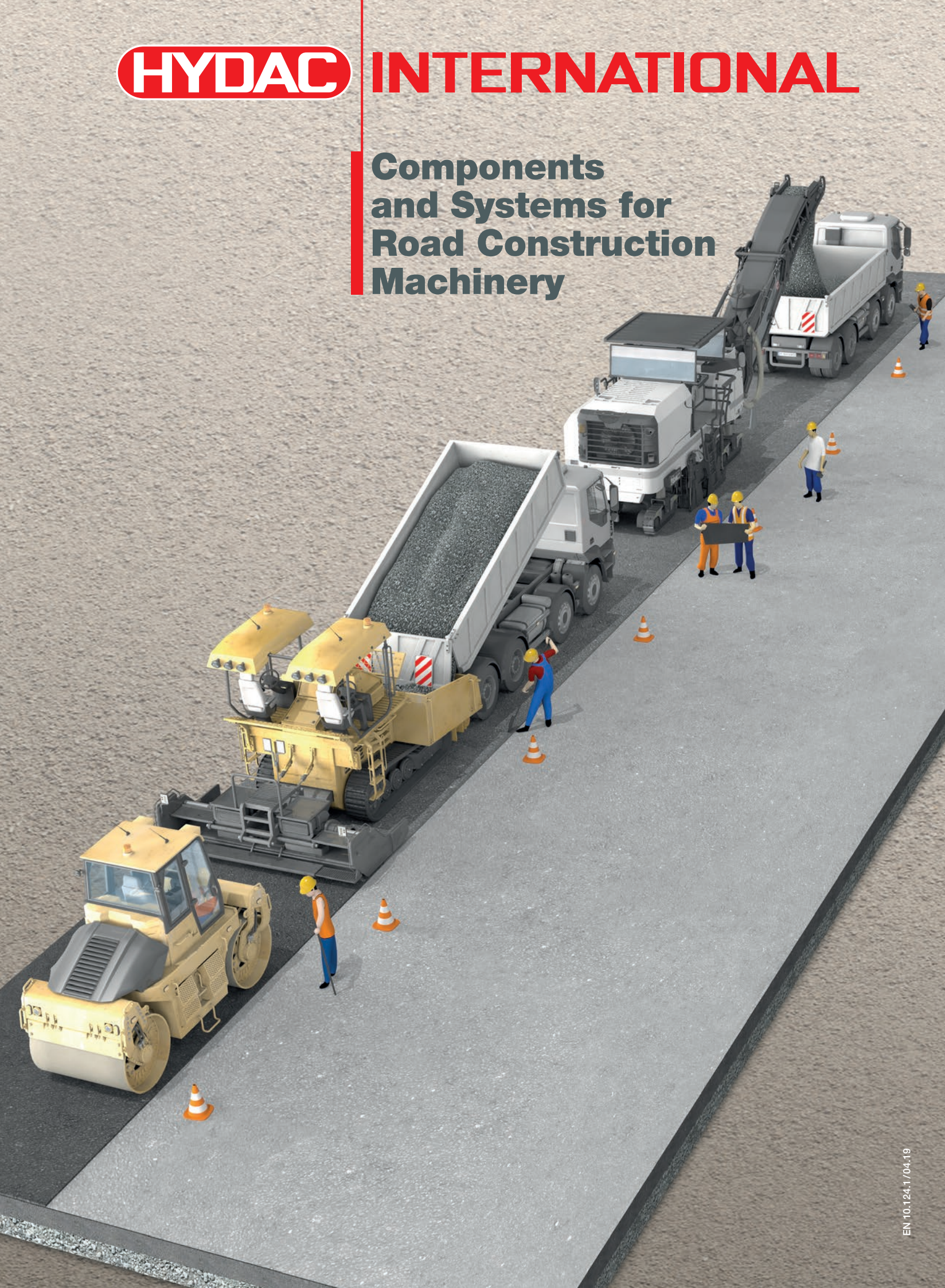

Components and Systems for Road Construction Machinery



HYDAC Head Office in Germany



HYDAC China



HYDAC Japan



HYDAC Korea



HYDAC USA



HYDAC France



HYDAC Italy

Note

The information in this brochure relates to the operating conditions and applications described. For applications and/or operating conditions not described, please contact the relevant technical department.

All technical details are subject to change without notice.

Since it was founded in 1963, HYDAC's constant innovative development has helped it to become a company group with some 9,500 employees, with a presence in almost all industries.

In addition to existing components, HYDAC can provide system solutions customised to suit your specific fluid power and electronics requirements.

To help us with this, we have established a mobile technology engineering team that can use our company's expertise to assist you.

This enables HYDAC to provide you with worldwide comprehensive engineering services in consulting, joint development and trials which will both aid the realisation of your projects and support the services you provide.



All of this is based on our extensively tried-and-tested, top-quality hydraulics and electronics range. We also perform work to DIN ISO 9001 as a matter of course.

For detailed information on our products, please do not hesitate to contact us directly. For joint project drafting and systems, please get in touch.



Contents

Page

Applications for...

Road Milling Machines and Soil Stabilisers	4
Asphalt and Concrete Pavers	6
Asphalt and Earthworks Compactors	8

Components and Systems for...

Control Technology and System Intelligence	10
Collaboration	13
Sensors, System Electronics and Displays	14
TTConnect Cloud Service	15
Valve and Control Block Technology	16
Convenience Systems and Components	18
Hydraulic Supply	20
Filtration, Air Separation and Tank Optimisation	22

Additional Solutions

Accessories	24
Cylinder Systems	24
Fluid Condition Monitoring and Fluid Conditioning	25
Service Tools	25
Technical Cleanliness	26
HYDAC KineSys Electro-Cylinders for Mobile Applications	26

Trends...

in Traction Hydraulics and Working Hydraulics in Mobile Machines	27
--	----



Applications for Road Milling Machines and Soil Stabilisers



Cab Roof and Bonnet Adjustment



- To lift/lower the cab roof and bonnet with integrated leakage-free load holding
- Includes hand pump for emergency operation of both functions

Loading Belt Control

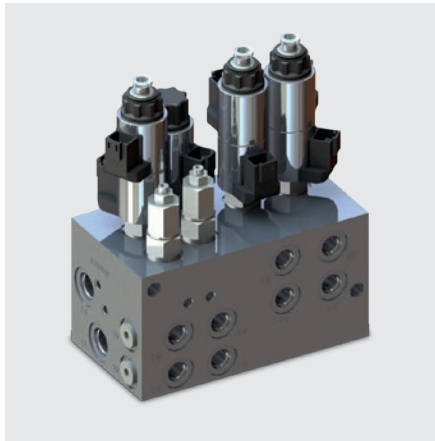

- Lifting and lowering of loading belt
- Right/left swivelling of the loading belt
- Folding the loading belt (into transport position)

Levelling Control Block

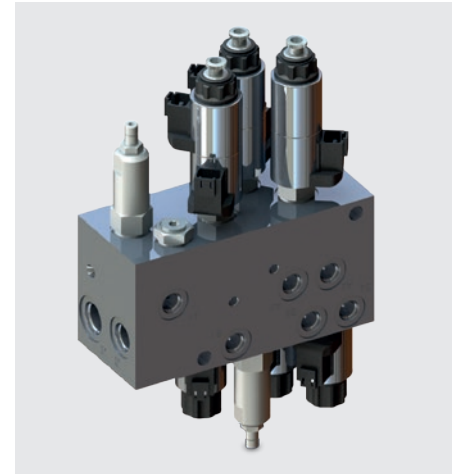

- For levelling off the mill during operation to ensure an even surface
- The levelling is performed in interaction with the linear position and tilt sensors in the four individual chassis cylinders

Chassis Control Block



- To control the front or rear steering
- Adjusting the height of the chassis right/left
- Bulkhead plate control (lift/lower), to prevent milled material from escaping during milling
- Position retention with leakage-free poppet valves

Modular System for Working Hydraulics, Chassis and Steering

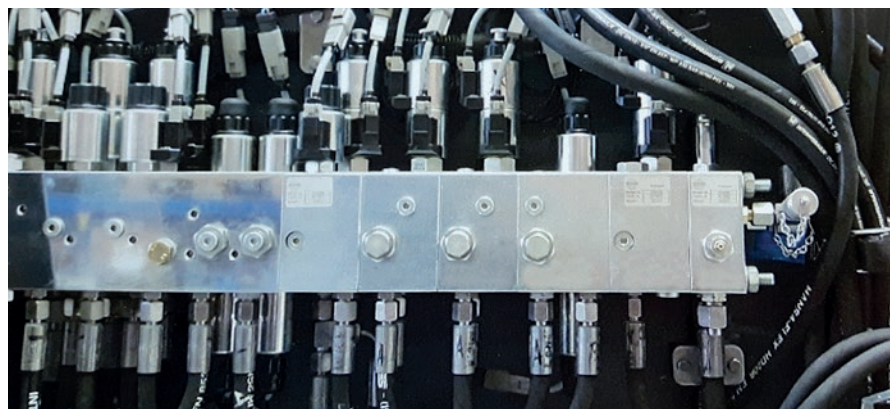

The following functions can be integrated directly or on an optional basis depending on the configuration level:

- Height adjustment right/left
- Edge protection right/left
- Folding of the right-hand drive gear for rim or edge milling (track widening)
- Chisel/tool change
- Remote control of various belt conveyors
- Proportional steering/additional steering
- Lift/lower protective roof
- Drum flap
- Levelling boom

CMS Combination Cooler

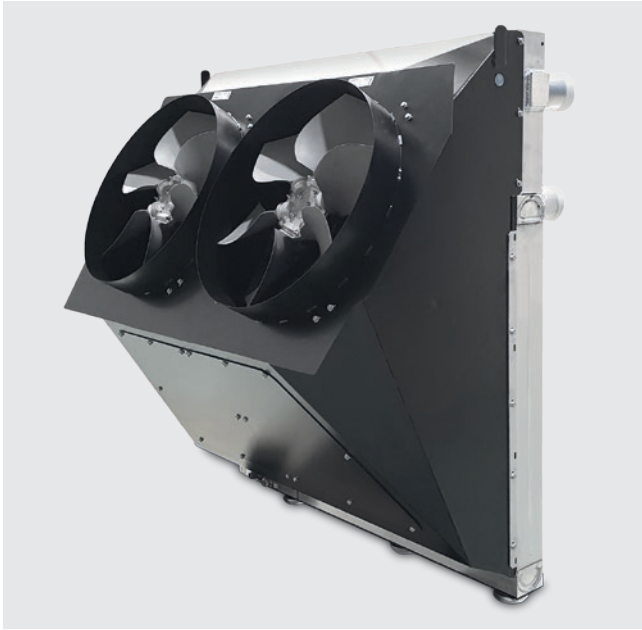

Cooling circuits:

- Charge air
- Coolant
- Hydraulic oil
- Compact design: Optimum arrangement of the heat exchangers for optimum performance
- Use of two small fans, reduced fan power consumption
- Cooling air exits upwards to ensure a reduced noise level

Chassis Cylinders for Crawler Drives



The cylinder is attached to the crawler chassis of a road milling machine and is used to configure the height of the crawler chassis.

The cylinder is rotated about its longitudinal axis to steer the crawler chassis.

The piston rod can rotate in the cylinder at the stop on the cover or base (bronze welded on to rod end, bronze disc the top of the piston).

The chassis cylinder is supplied with oil via the rod head.

Hydraulic Filtration

The RKM return line suction filters are the interface between the open circuit of the working hydraulics and the closed circuit of the traction drive.

The return line flow is finely filtered and some of it is pressurised (0.5 bar) and supplied to the boost pump.

With an optional integrated thermocooler bypass valve, some of the return line flow can also be conveyed via the oil cooler.

DC Small Power Pack for Hydraulic Supply

Used to supply small consumers during maintenance or emergencies to prevent the main hydraulics from being used.

- Enables slow turning of the milling roller for chisel change
- For lifting / lowering the milling roller, bonnet or cab roof
- For emergency steering at 100% duty cycle, so that the mill can be driven from the road

Applications – Control Technology

Displays

- Programming in CODESYS or C
- New outdoor variant for the HY-eVision² display, with bonded display specially designed for off-road applications (machinery without a cab)

Controllers

- Programming in CODESYS or C
- 30 to 96 inputs and outputs
- Certified controls



Applications for Asphalt and Concrete Pavers



Hopper and Spreading Auger Control



- For positioning the asphalt receiving hopper
- For adjusting the height of the spreading auger

Optional Screenshot Adjustment Module

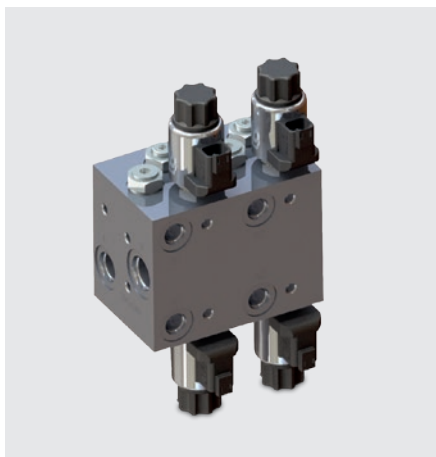

- For height and width adjustment of the screed
- Leakage-free cartridge valve for load holding

Manual Control in Emergency and Set-up Operation

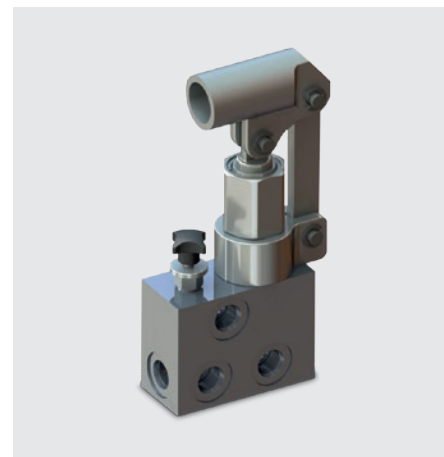

- Control block with hand pump and unloading valve**
- For lifting/lowering the cab roof and bonnet
 - For manual release of the parking brake in emergency operation

Conveyor Belt Control



- Control block for proportional control of the installation, conveyor belt and/or auger speed

Applications – Control Technology



Displays

- Programming in CODESYS or C
- New outdoor variant for the HY-eVision² display, with bonded display specially designed for off-road applications (machinery without a cab)

Controllers

- Programming in CODESYS or C
- 30 to 96 inputs and outputs
- Certified controls

LS-Controlled Working Hydraulics

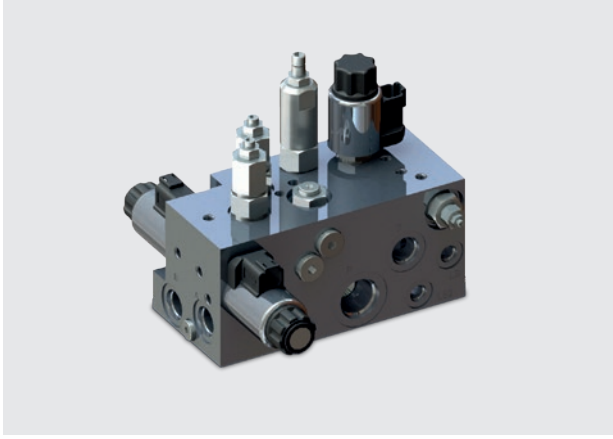

- Prioritised steering function
- Supply to the working hydraulics
- Parking brake is fed via the pressure reducing valve

Working Hydraulics as a Modular System

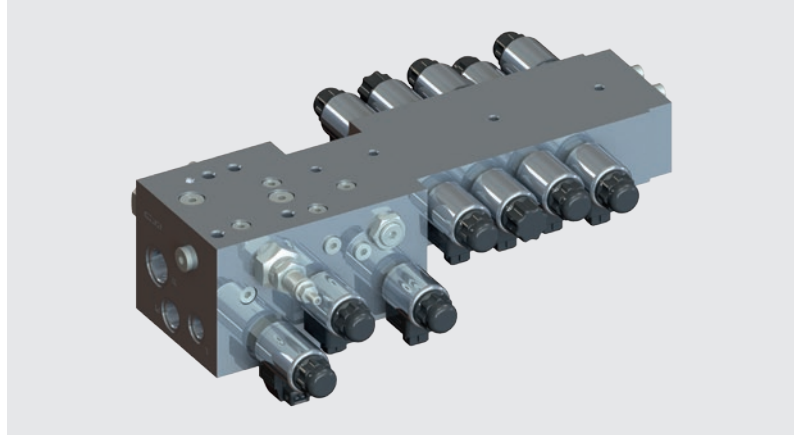

Depending on the configuration level, various functions can be integrated or subsequently upgraded:

- Proportional control of the hopper conveyor belts
- Proportional control of the spreading augers
- On/off screed height adjustment, incl. pressure application
- On/off screed angle adjustment

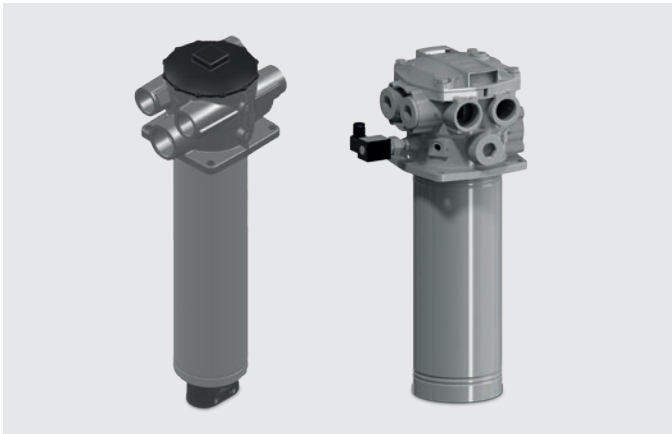

Hydraulic Filtration

The RKM return line suction filters are the interface between the open circuit of the work hydraulics and the closed circuit of the traction drive.

The return line flow is finely filtered and some of it is pressurised (0.5 bar) and supplied to the boost pump.

With an optional integrated thermo-cooler bypass valve, some of the return line flow can also be conveyed via the oil cooler.

CMS Mobile Cooler for Road Pavers

In a CMS mobile cooler, various cooling circuits are combined.

- Charge air cooling (CAC)
- Coolant cooling (RAD)
- Hydraulic oil cooling
- Fuel cooling
- Also available with hydraulic fan drive

If required, an air conditioning condenser can also be integrated into the cooling system.



Applications for Asphalt and Earthworks Compactors



Edge Cutter Control

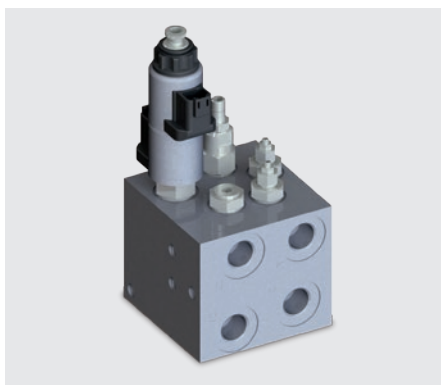

For clean and perpendicular cutting of the asphalt edge, for smooth transitions to the next asphalt layer.

- Lifting/lowering of edge cutter, incl. pressure limiting
- Transport safety provided by leakage-free poppet valves

Vibratory Control



- Switches vibration drive on/off in the drums
- Smooths pressure spikes during vibration start-up to protect the motors
- Optimises vibration switch-on and switch-off times to achieve a rapid vibration stop (3–5 seconds)
- Frequency change-over and pressure limiting

Manual Control in Emergency and Set-up Operation



Control block with hand pump and unloading valve

- For lifting/lowering the cab roof and bonnet
- For manual release of the parking brake in emergency operation

Electro-Hydraulic Differential Lock

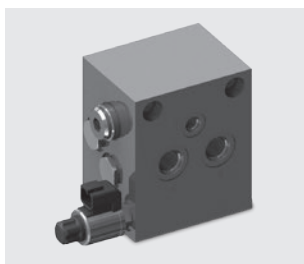

For even distribution of the flow of force to the traction motors:

- If slippage of a traction motor occurs, the hydraulic 4/2 valve is controlled via a 3/2 directional valve and the oil flow rate is forcibly guided via a flow divider.

Emergency Stop Valve

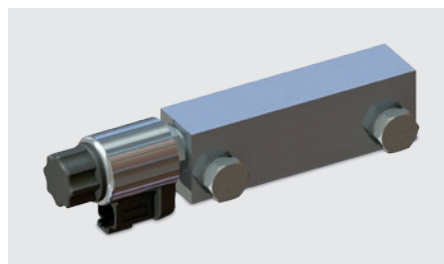

For automatic interruption of the traction drive and immediate roller stop.

- Contact switch for control



Applications – Control Technology

Displays

- Programming in CODESYS or C
- New outdoor variant for the HY-eVision² display, with bonded display specially designed for off-road applications (machinery without a cab)

Controllers

- Programming in CODESYS or C
- 30 to 96 inputs and outputs
- Certified controls

Main Steering – Steer-by-wire

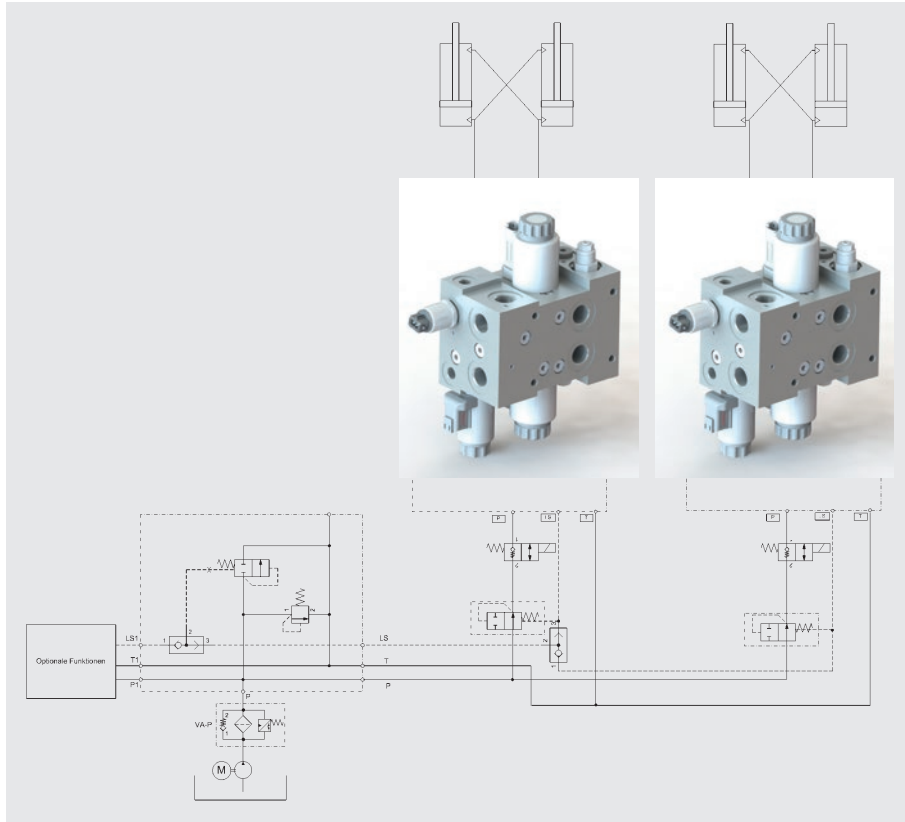

For tandem vibration rollers, HYDAC has developed an electro-hydraulic steer-by-wire steering system.

The various steering programs (steer modes) enable effective rolling and manoeuvring even in very constricted road radii and in restricted spaces.

With the crab steering mode, the asphalt can be compacted up to the kerb via the drum offset.

CMS Mobile Cooler for Light Tandem Rollers



In a CMS mobile cooler, various cooling circuits are combined.

- Charge air cooling (CAC)
- Coolant cooling (RAD)
- Hydraulic oil cooling
- Fuel cooling
- Optionally available with hydraulic fan drive



Fan control block

If required, an air conditioning condenser can also be integrated into the cooling system.

Compact Hybrid Solution

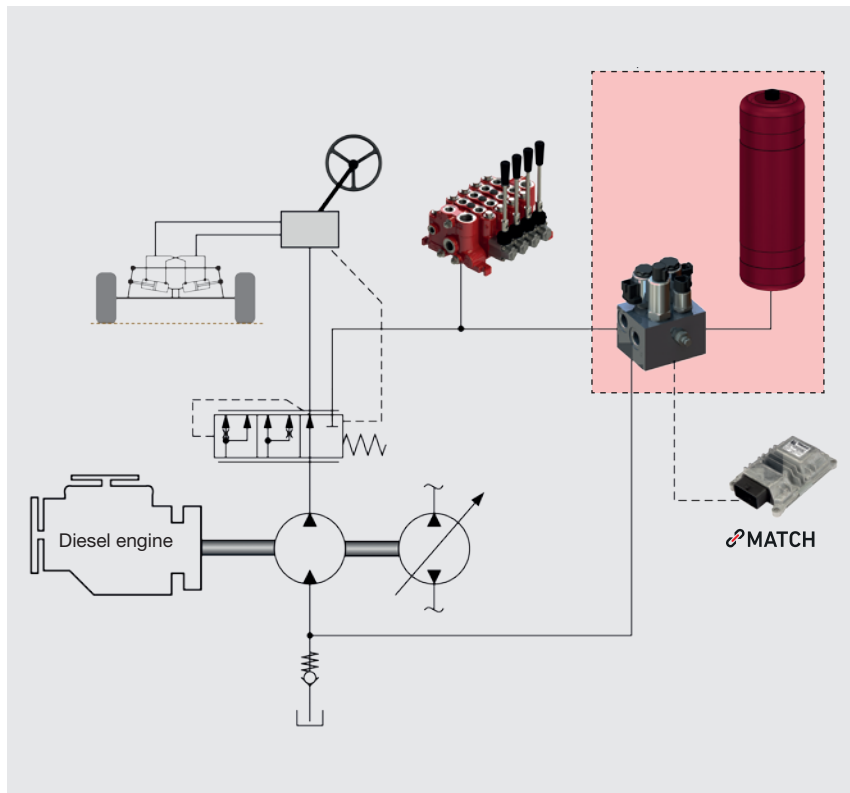

The stage V rules that came into force on 1 January 2019 bring new requirements for exhaust gas treatment in diesel engines in mobile working machinery. Compliance with these rules entails increasing costs and high installation space requirements for exhaust gas treatment systems. Many mobile machines and in particular asphalt rollers in the range of 19 to 35 kW have load cycles with characteristic load peaks. The mean cycle performance is, however, often below 19 kW. One possible approach for these machines is a hybrid approach that takes into account the existing drive topology with hydraulic prioritisation of the steering system. As the adjacent figure shows, the hydraulic accumulator that is incorporated into the hydraulic system is charged with third priority. Load peaks can be covered by power input on the suction side of a suitable work hydraulics pump, which then works as motor. This enables a significant downsizing of the diesel engine.

Advantages:

- Reduction in system costs thanks to a smaller diesel engine and simpler exhaust gas treatment
- Reduced fuel consumption
- Simple integration into the existing hydraulic system
- Flexible adaptation to various machines and operating conditions

Control Technology and System Intelligence

System Intelligence

Electro-hydraulic system solutions as an interface between actuators and sensors.

The demands of modern road construction machinery are leading to the ever-increasing complexity of control systems. Modern machines require a variety of assistance and control systems whenever simpler operating concepts, a better overview and controllability of the machine functions become necessary.

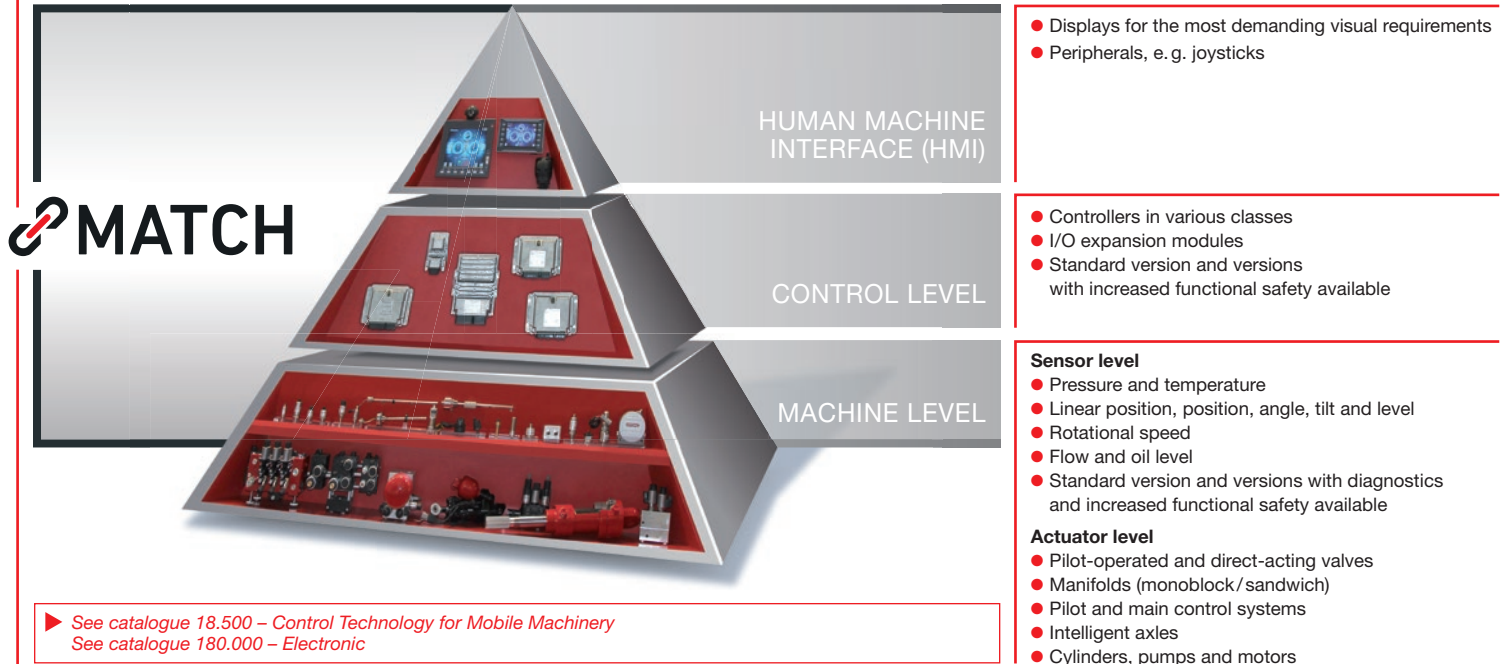

System Development

When developing electro-hydraulic control systems for mobile machinery, HYDAC offers comprehensive support which is tailored to the customer's requirements. The scope of development is determined together with the customer and is customised to suit the task at hand.

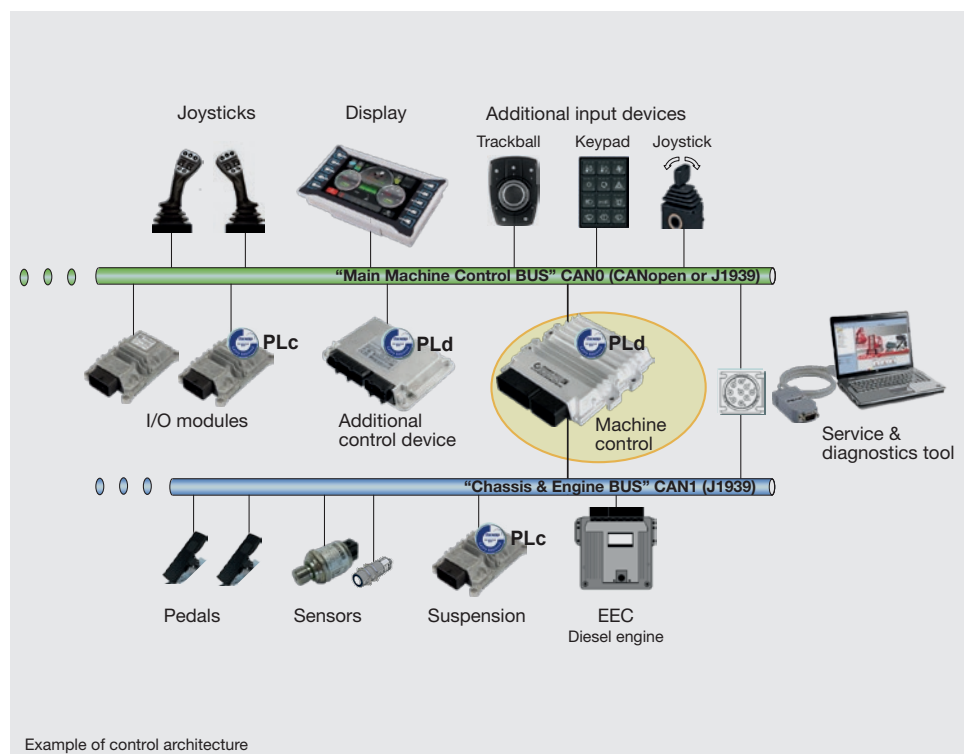

Services include:

- Creating customer-specific application software (according to the requirement book)
- Integrating intelligent subsystems into the customer's machine (e.g. suspension systems, additional steering systems, fan controls)
- Complete control solutions for mobile machinery (safety functions, electrical/electronic control architecture, application software)

Software Development

Depending on the hardware, the following programming languages can be used to program the application software:

- CODESYS 2.3 / 3.5 / 3.5 SIL2
- C

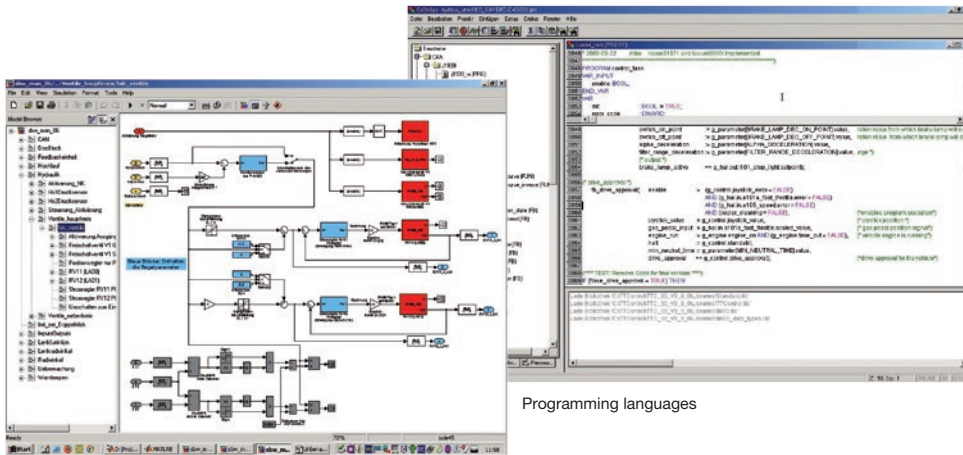

Programming languages

System Development Support

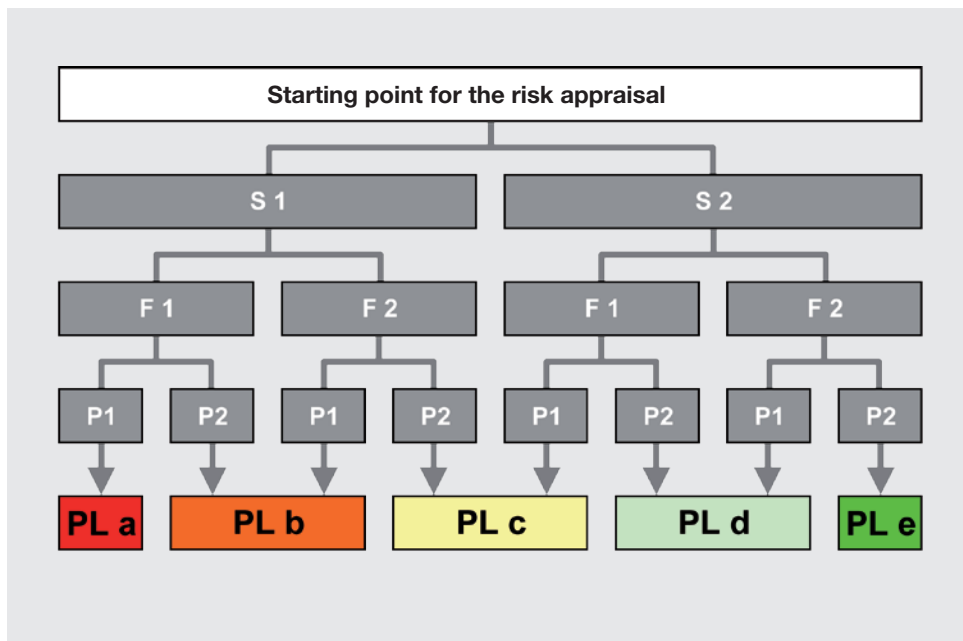

Seriousness of injury

- S1 Minor, reversible injury
- S2 Severe, irreversible injury including death

Frequency / duration of exposure to the hazard

- F1 Rare or brief exposure to hazard
- F2 Frequent to continuous exposure to hazard

Possibility of avoiding the hazard or limiting the damage

- P1 Possible under certain circumstances
- P2 Practically impossible

HYDAC offers extensive consultation and support for customer projects with regard to:

- Hazard and risk (H&R) analysis
- Definition and description of safety functions
- Drafting safe system architectures and user interfaces (HMIs)

Control Technology and System Intelligence

“MATCH” Development Environment

MATCH Machine Application Tool CHain

Development environment for mobile working machines

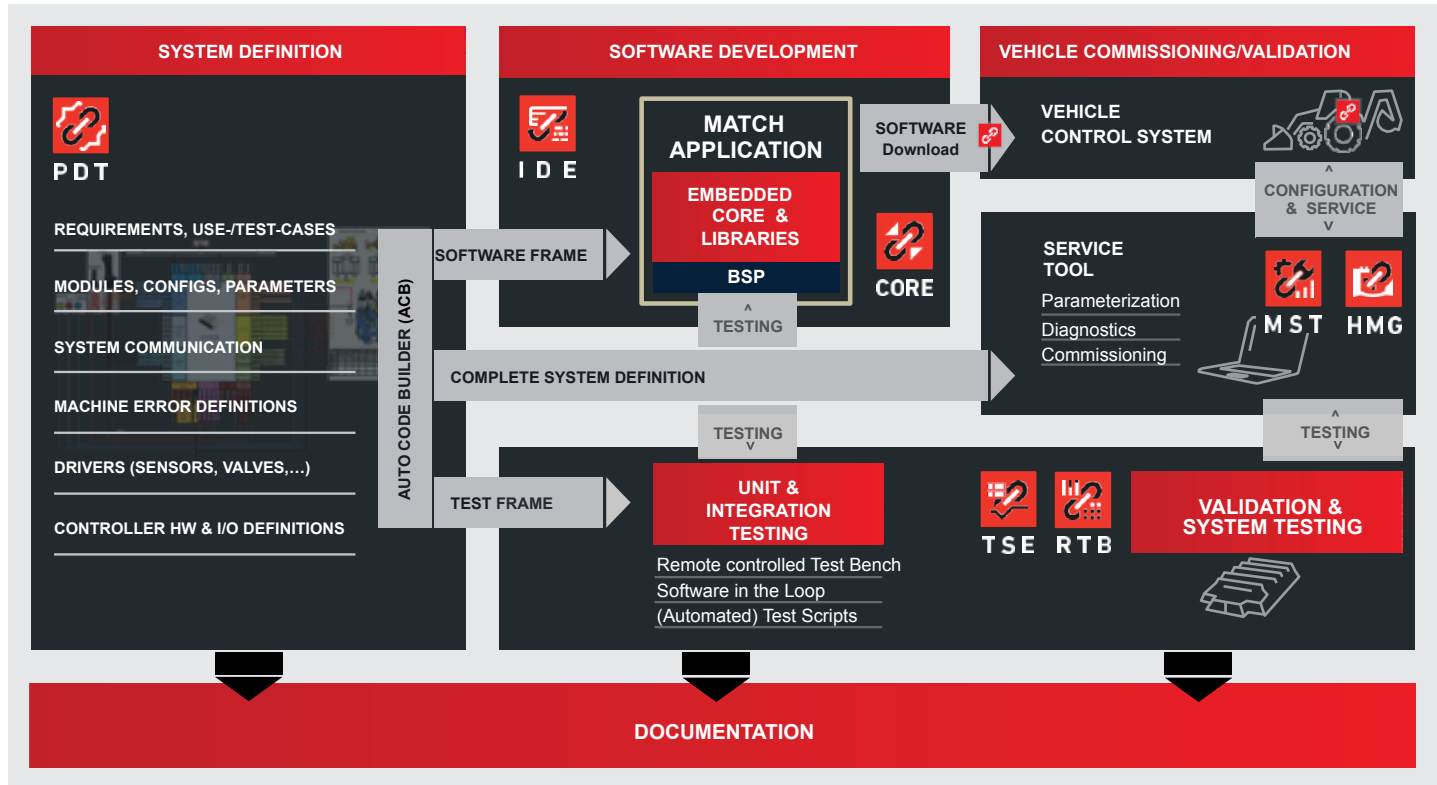

MATCH integrative tool chain approach

With “MATCH” (Machine Application Tool CHain) software, HYDAC offers a tool chain for customer-driven, system-level software development that is tailored to the requirements of mobile machinery.

“MATCH” supports development right from defining the system at the vehicle level and creating the application software to start-up, testing, and documentation.

“MATCH” offers modules for:

- Defining the system at the vehicle level
- Starting up and servicing the machine
- The software test (e.g. via HYDAC Electronic RTB Box)
- Documentation

“Embedded middle ware” is also offered. This enables the application to be programmed without hardware and contains a multitude of basic functions. A comprehensive selection of library modules (e. g. for sensor and valve drives) is also available for efficient application software development.

Functional safety

- MATCH can also write application software with increased functional safety according to the following safety standards with TÜV certification:
- SIL 2 to IEC 61508
- PL d to EN ISO 13849
- AgPL to ISO 25119 / DIN EN 16590



▶ See catalogue 18.500 – Control Technology for Mobile Machines

▶ See micropage – match.hydac.com

Simulation Technology

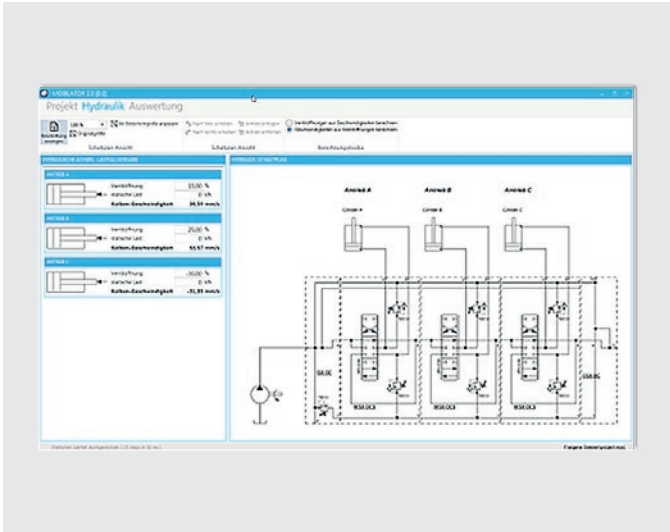

The quality of a hydraulic system is determined by a well-coordinated interplay between a number of single components such as pumps, cylinders, motors, valves, accumulators, piping and electronic components.

When there are strict requirements for the system dynamics, the precision of control processes and safety-relevant functions, it is especially vital for detailed information on the expected operating behaviour to be made available as early on as possible.

Hydraulic simulation makes it possible to perform extensive system analyses and optimisations in the early development phases, minimising time-consuming and costly re-design and work in the test field.

Using hydraulic simulation in conjunction with the simulation of multi-component systems also makes it possible to take into account the effect of complex kinematic structures and their retroactive effect on drive behaviour.

Networked Specialists for...

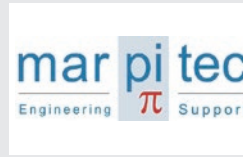

Animations



Simulations



MATCH
Development Software



Development Environments



Telematics Solutions



Data Analysis



Functional Safety

Sensors, System Electronics and Displays

Sensors



Function

The range of sensors includes products for the measurement of pressure, temperature, linear position, position, level, flow volume, rotational speed, tilt and angle as well as contamination and oil condition. In addition to products for standard applications, the product portfolio covers special applications such as potentially explosive atmospheres or applications with increased functional safety.

Electronic sensors and controls which complement the system electronics:

- Max. load regulation
- Electro-hydraulic load sensing
- Working hydraulics
- Positioning
- Controls of special equipment
- Cut-off devices
- Safety systems

Features

- The sensors are available with a variety of output signals, electrical connectors and connection options
- Robust design
- ECE type approval
- Approved for potentially explosive atmospheres
- Separate product portfolio, specially designed for applications with increased functional safety (SIL 2, 3/PL c, d)

Mobile Controller and I/O Expansion Modules

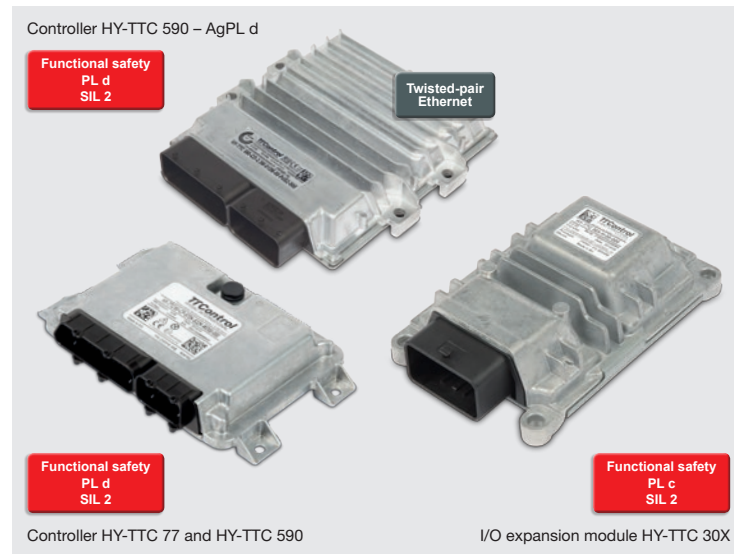

Function

With the HY-TTC series of controllers, HYDAC offers the right platform for a wide variety of requirements and applications. HYDAC's controllers are always efficient, safe, reliable and flexible. The controllers are designed for use both in complex centralised control architectures and in decentralised ones. HYDAC supplies the right controller for each machine size. The controllers can be classified into the following groups which are based on the number of inputs and outputs: the HY-TTC 30 with up to 30 I/Os, the middle group HY-TTC 50/90 with up to 50 I/Os and the HY-TTC 500 family, covering a wide scope, with even up to 96 I/Os. The highly flexible configurations of inputs and outputs make solutions possible for all kinds of functions and machine types.

The HY-TTC 30X series of I/O expansion modules provides an outstanding power balance combined with an extremely compact design. They can be easily be integrated into the existing wiring systems.

Thanks to their internal diagnostic and monitoring functions, the controllers and I/O expansions are also suitable and certified for tasks with increased safety requirements up to SIL 2/PL d. The I/O expansion modules are certified to SIL 2/PL c.

Features

- Depending on version, certified to SIL 2/PL d
- PL c for HY-TTC 30XS
- Programming in C/CODESYS
- 30/50 or 96 inputs and outputs
- All inputs and outputs are configurable and are protected against overvoltage and short circuits
- Stabilised sensor voltage supply with internal monitoring
- No reset caused by voltage drop when starting engine
- Aluminium die cast housing with waterproof connection plugs, including a waterproof Gore-Tex membrane for hydraulic balance
- E12 type approval

▶ See catalogue 180.000 – Electronic

▶ See catalogue 18.500 – Control Technology for Mobile Machines

TTConnect Cloud Service

Vision Mobile Displays



Displays with integrated HY-eVision² controller

Function

The compact, background-lit TFT colour displays with an integrated high-end display controller are characterised by a very high image quality, low reflections and high colour saturation as well as optimal readability, even under the most unfavourable light conditions.

The displays are protected by a robust aluminium or plastic housing and can be either built directly into the instrument panel or surface-mounted in the field of vision of the driver/operator using a RAM Mount[®] system in the cockpit.

Freely programmable illuminated control keys along with the touchscreen feature create an easy-to-use human-machine interface.

Up to four external cameras can be connected to the display via the integrated video ports or Ethernet. These can be controlled with software.

Features

- User-friendly, self-explanatory and time-saving graphical design and operation interface
- Good portability via CODESYS platform
- High image brilliance
- High refresh rate
- Rapid bootup time and additional sleep mode
- Impressive display options such as 3D, picture-in-picture and overlapping effects
- Two images can be displayed simultaneously
- Up to four CAN, USB and Ethernet interfaces
- Robust housing with appealing design, suited for mobile applications
- Standby & wake-up

Telemetry TTConnect

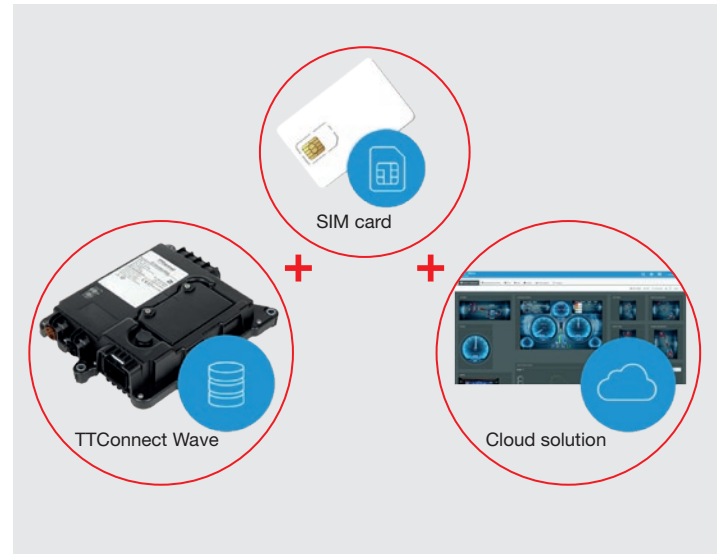

Description

The solution enables OEMs and fleet owners to draw the maximum benefit from their machine data and to implement services such as monitoring and machine management using minute-by-minute based machine information on its status, operation and location.

Selected vehicle data can easily be logged, stored and visualised. The vehicle's display can be replicated and interacted with at a remote location if service is required. Vehicle updates can be started at the touch of a button.

The TTConnect cloud platform includes the TTConnect Wave hardware unit (IoT gateway) – the sector's simplest and most comprehensive solution for connecting vehicles and aircraft fleets with the TTConnect cloud service platform, an M2M SIM card and access to the cloud platform.

Features

- Robust design for extreme operating conditions
- No programming knowledge required
- Simplicity: everything can be controlled from the website platform
- Data logging
- GPS/Glonass
- ECU firmware updates
- In-vehicle communication and messaging
- Cellular or wireless LAN connectivity
- Secure end-to-end encryption
- CE/E, FCC, IC certified for operation in Europe, the USA and Canada

▶ See catalogue 18.500 – Control Technology for Mobile Machines

▶ See catalogue 18.500 – Control Technology for Mobile Machines

Valve and Control Block Technology

The perfect working hydraulics for rapid, precise and efficient control.

Valve Technology



HYDAC looks back on decades of experience in valve technology. Over the years, HYDAC has constantly expanded its range of individual valve types. This has resulted in an extremely extensive and comprehensive product range which enables the design of almost all hydraulic systems – whether these are stationary or mobile. Whether it's directional spool, directional poppet, pressure, flow, shut-off, cartridge, plug-in, manifold-mounted, sandwich plate or pipe valves – we have the perfect valve for your system.

HYDAC is always a reliable contact even for customer-specific requirements, thanks to its high level of expertise and modular component system.

Advantages at a glance

- Very broad product range (full-liner for cartridge valves) and great flexibility for accommodating customer wishes thanks to the modular system
- Extremely high level of in-house manufacturing: in-house coils, pole tubes and valve assembly
- Extensive know-how thanks to decades of experience in valve technology
- Customised valves tailored to the particular application
- High quality and strong performance
- High functional reliability and stability
- Long life expectancy with maximum performance values
- Simple integration into systems/valve blocks

Open Center Primary Control Valves



RS series



RM series



DX series

Load-Sensing Main Control Valves

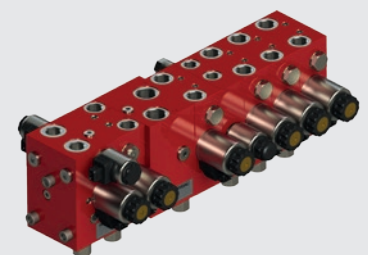

HX-1 series



LX-3 series



LX-6 series

▶ See catalogue 53.000 – Compact Hydraulics

HYDAC's open center main control valves offer you a modular system with which to design robust, energy-efficient and cost-effective open center controls for mechanical, pneumatic, hydraulic and electro-hydraulic control.

Properties

- Structural design as monoblock, multi-section and disc construction
- Key data: $Q_{max} \leq 180$ l/min; $p_{max} = 350/400$ bar
- Energy-saving Q-inlet option
- Robust, high quality and maximum controllability
- Low internal leakage
- Inlet switching for safe flow distribution
- Electrical pump flow cut-off
- Main actuators with parallel, series and tandem control
- Simple integration of secondary safeguards
- Optional switch position monitoring of the main control spool
- Can be used to control LS variable displacement pumps

Key data for open center main control valves (see images on left):

- RS series → $Q_{max} =$ up to 120 l/min; $p_{max} =$ up to 300 bar
- RM series → $Q_{max} =$ up to 140 l/min; $p_{max} =$ up to 300 bar
- DX series → $Q_{max} =$ up to 140 (180) l/min; $p_{max} = 350/400$ bar

HYDAC's load-sensing main control valves offer you a modular system with which to design load-compensated, energy-efficient load-sensing controls for mechanical, pneumatic, hydraulic and electro-hydraulic controls.

Properties

- Structural design as multi-section and disc construction
- The LX-3 series has a large 8 mm piston stroke for the best precision control
- Load-independent parallel actuation is possible without reciprocal influencing
- Simple integration of primary/secondary safeguards
- Inlet switching for safe flow distribution
- Electrical pump flow cut-off
- Optional switch position monitoring of the main control spool
- Optional switch-off of individual sections with complete functionality of the remaining sections
- Modular valve combinations adjusted to suit the flow rate, e.g. LX-6 + HX-1; LX-6 + LX-3

Key data for load-sensing main control valves (see images on left):

- HX-1 series → $Q_{max} = 120/35$ (prop) l/min; $p_{max} = 250$ bar
- LX-3 series → $Q_{max} =$ up to 90 l/min; $p_{max} = 350/420$ bar
- LX-6 series → $Q_{max} =$ up to 180 /min; $p_{max} = 350/420$ bar

▶ See brochure no. 5.254 – Mobile Valves

ICU – Motor Actuation with On-Board Electronics

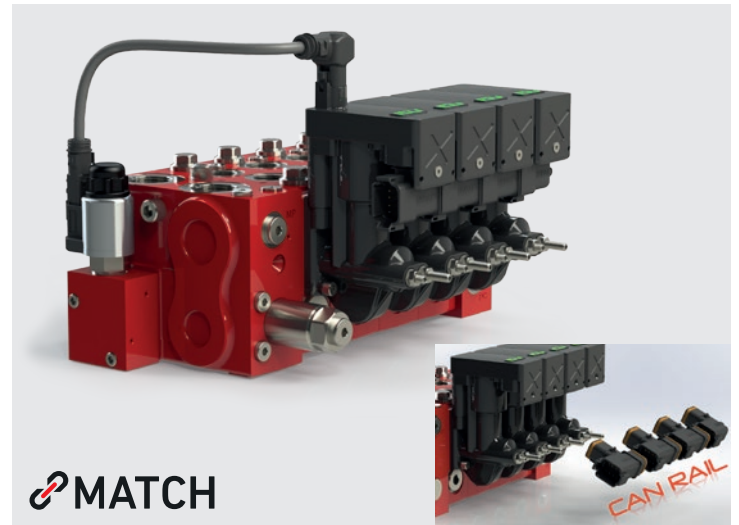

With the ICU (Intelligent Control Unit), HYDAC has developed a new control type with on-board electronics for mobile valves from the LX series.

The brushless, electronically controlled motor provides high precision and a rapid stepped response.

The CAN control is effected via a CAN rail connection, eliminating the need for a cable harness for individual directional valves. It is MATCH-compatible and fulfils protection types IP67 and 6K9K.

Customised Solutions

We work with you to develop individual all-inclusive system solutions for your particular application, customised to suit your device. In addition to the hydraulic components, we can also provide extensive development and manufacturing expertise in relation to electronics and software.

Application-specific – tailored to needs – custom-made.

We offer:

- Dimensioning adapted to suit the required functions
- Integration of valve technology, accumulators, filters, sensors and software
- Weight-optimised, space-saving designs
- Project planning, consulting and support for the implementation of customer-specific projects provided by specialist personnel at our in-house application centre
- Customer machinery tests at our in-house test site

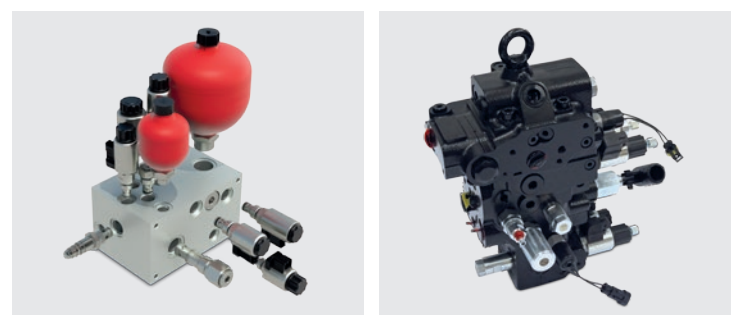

Convenience Systems and Components

Electro-Hydraulic Main and Additional Steering Systems EHZ

Our EHZ system modules offer a highly flexible foundation for the electro-hydraulic steering of all kinds of vehicles.

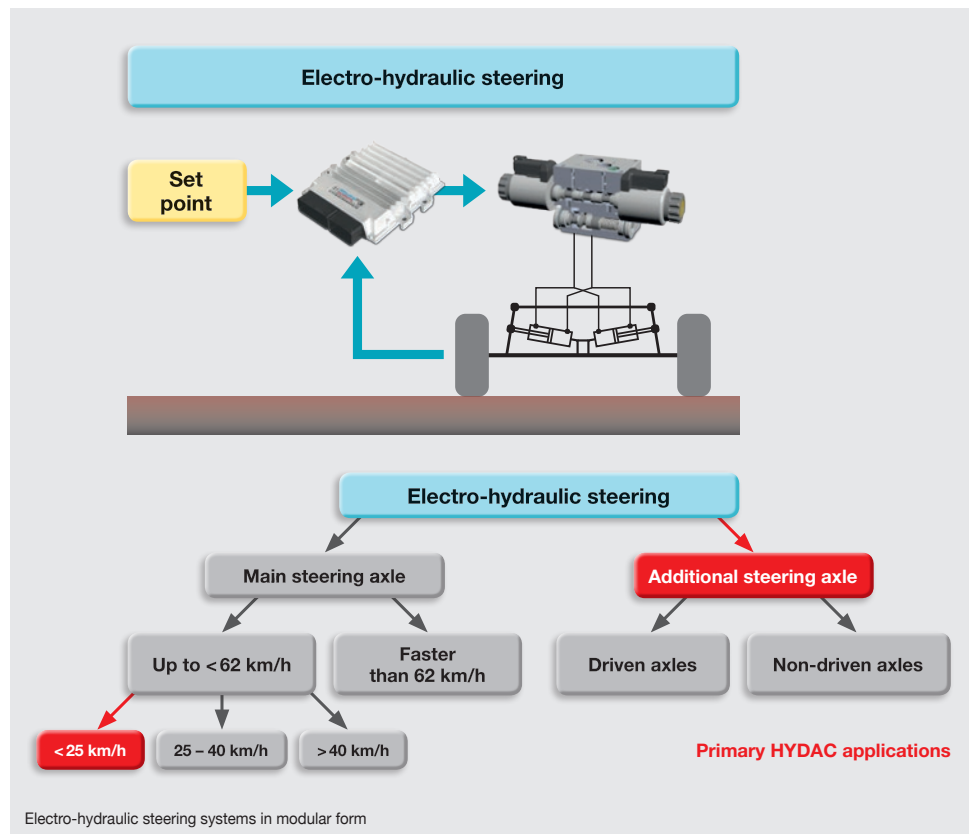

Electro-hydraulic steering and additional steering systems enable various types of steering to be realised in self-propelled and trailed working machines. For self-propelled vehicles, various special types of driving (such as all-wheel and crab steering) are possible in addition to the normal driving varieties. In combination with the hydraulic steering systems for the front axles, electro-hydraulic master control steering systems and additional steering systems for the rear axles are possible. For trailed working machines, we can use our modular steering valves to meet the various steering requirements for additional steering in the second axle with optional free wheel or lock-out circuits for the steering cylinders.

Applications

- Front axle steering
- Rear axle steering
- All-wheel steering
- Unlimited number of controllable axles
- Different safety concepts can be selected



STEER-by-wire

Main steering

Advantages

- Work and steering functions provided by one control element
- Driver's stand is easy to move
- Steering sensitivity can be adjusted
- Assistance systems are easy to integrate

Application examples

- Forestry machinery
- Off-road vehicles/machines

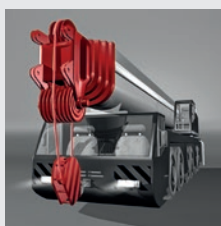

STEER Additional

Additional steering

Advantages

- Turn radius reduced
- Lower tyre wear
- Various steering programs
- Speed-dependent steering steering behaviour

Application examples

- Trailers, loading cars, field sprayers
- Truck/commercial vehicle trailing axles
- Vehicles with multiple axles



STEER Assistance

Alternative hydraulic steering

Advantages

- On-road = exclusively hydraulic steering system, Off-road = steer-by-wire
- Default level is always the hydraulic steering system
- Increased driver comfort provided by driver assistance systems

Application examples

- Self-propelled harvesting machinery
- Wheel loaders, telescopic handlers
- Mobile machines
- Handling machines

▶ See brochure 10.116.9 – HY-STEER Electro-Hydraulic Steering Systems

Electro-Hydraulic Steering Valves



Steering system modules & electronics

The steering valve module can be supplied for use in all standard hydraulic systems thanks to its varied designs. Our proportional steering valves have been specially optimised for use in hydraulic steering systems. In the series, the basic version is designed for one steering axle and can be fitted with expansion modules for the remote control of additional steering axles.

Advantages

- Can be connected to all pump types
- Unlimited number of steerable axles
- Different safety concepts can be selected
- Assistance systems are easy to integrate
- Hydraulics and electronics combined in a single system
- From the component to the system – all from a single source

▶ See brochure 10.116.9 – HY-STEER Electro-Hydraulic Steering Systems

Hydropneumatic Suspension Systems



Chassis suspension

Cab suspension

Chassis and cab suspension

Intelligent axle suspension system with locking function and adjustable driving characteristics to improve driving stability and thus increase performance.

Cab suspension system with electronic component to reduce driver exposure to vibrations and increase comfort.

▶ See brochure 10.116.4 –
Hydropneumatic Suspension Systems for Lightweight Commercial Vehicles
See brochure 10.116.6 – Cab Suspension Element

Accumulator Technology



Bladder, piston and diaphragm accumulators for mobile applications

Accumulators

HYDAC offers an exceptionally wide product portfolio of accumulators and dampers for a very wide array of hydraulic applications involving mobile machines. Accumulators enhance the working comfort and functionality of the machines and therefore minimise stress for both humans and machines.

Typical accumulator tasks and benefits resulting from them include:

- Power supply for emergency functions
→ increase in performance with comparatively equal technical conditions
- Pulsation damping in the hydraulic system
→ longer life expectancy of attached parts due to minimisation of vibrations
- Energy storage to safeguard the vehicle system and to compensate for leakages
→ vehicle braking systems, rotating mechanism brake, parking brake, etc.
- Emergency and safety tasks in the pilot circuit
→ increase in functionality
- Use in hydropneumatic suspensions
→ increased driving stability and operator health

Advantages

Our accumulator specialists have decades of experience in the development and design of all types of accumulators at their disposal. This means that they are in the position to select the suitable accumulator type for the application from our comprehensive product range and configure it in accordance with operating conditions. The right accumulator is still the best support for an application, whether country-specific approvals or MULTI-approvals are required. HYDAC accumulators can be used worldwide.

▶ See catalogue 30.000 – Accumulator Technology

Hydraulic Supply

Cooling

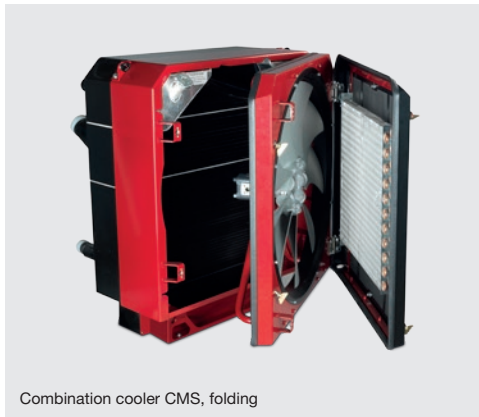

Combination cooler CMS, folding



Cooler-filter-tank unit



Oil cooler OK-ELD with electronic fan control

Combination coolers

The Emissions Directive for engines in mobile machinery has been structured to reduce emissions progressively, which can lead to a drastic increase in the required heat dissipation and a corresponding adjustment in cooler size. The generally limited installation space must therefore be utilised efficiently and intelligently.

Various cooling circuits are combined in a CMS mobile cooler, such as charge air, coolant, oil circuits (transmission and hydraulics) and diesel. If required, an air conditioning condenser can also be integrated into the cooling system.

The cooler dimensioning and simulation software KULI, which is also used in automotive applications, allows complex cooling systems to be modulated and calculated. Installation resistances and additional heat sources are thus taken into account in the cooler system calculation.

Cooler-filter-tank

Integrating the cooler, filter and tank allows multiple functions to be combined in one space-saving unit that is optimised for the installation space.

Hoses and pipes can thus be shortened or eliminated. The plastic hydraulic tank, which simultaneously functions as a fan cover, can also be optimised in terms of flow to enable noise reduction.

Plate heat exchanger

Compact, copper-brazed plate heat exchangers to dissipate the transmission oil or axle power loss to the hydraulic or water circuit.

Cooler bypass valve block

Combines the merging of multiple oil return lines with return oil temperature monitoring. Depending on the oil temperature, it can control the path so that it goes either directly to the tank or via the oil cooler to the tank.



Hydraulic oil cooling

Air coolers with DC motors (OK-ELD) or hydraulic motors (OK-ELK) are used to cool hydraulic oil. They are specially designed for mobile applications where a combination of high performance and easy installation in confined spaces is required.

- Robust and flexible aluminium plate design
- Contamination-tolerant high-performance air cooling fins
- Low-noise fan drives

To keep the oil temperature at a consistent level, the fan drive speed can be continuously adjusted to suit the required cooling capacity by a fan control (electronic or hydraulic design). These controls can also be supplied with a reversing function, to “purge” the cooler of dirt (e.g. dust and debris).

Fan controls

Hydraulic and electro-hydraulic controls for fan drive speed control with optional reversal of rotation direction for use with various types of pumps.

Valves specially developed for the application:

- Selector valves
- Suction valves
- Manually adjustable pressure relief valves
- Inversely proportional pressure relief valves

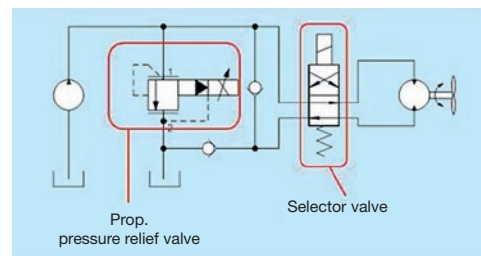

Example of fan control application

- ▶ See brochure 5.315 – A Breath of Fresh Air in Electro-Hydraulic Cooling Control

Drive Technology



The pump range covers fixed displacement, variable displacement and axial piston pumps of various designs from 0.25 cm³/rev to 560 cm³/rev and setting ranges up to 400 bar. The motor range covers displacement motors from 1 cm³/rev to 28 cm³/rev and setting ranges up to 300 bar.

HYDAC fixed displacement pumps for auxiliary circuits and pilot pressure supply

- External gear pump PGE from 0.25 cm³/rev to 60 cm³/rev, nominal pressure up to 250 bar and peak pressure up to 300 bar. Also available in multiple pump combinations.
- Internal gear pump PGI from 3 cm³/rev to 250 cm³/rev, nominal pressure up to 330 bar and peak pressure up to 400 bar. Also available in multiple pump combinations.

HYDAC axial piston pumps PPV100M for main functions

- From 3 cm³/rev – 100 cm³/rev, nominal pressure up to 315 bar and peak pressure up to 350 bar.
- Preferably for use in mobile hydraulics in open circulation systems. High setting range for safety reserves and a compact actuator system
- Highly effective thanks to high efficiency, long life expectancy, compact design, variable mounting position, modular controller strategy, service-friendly design

HYDAC displacement motors for transmission drives, e. g. fan systems

- External gear motor MGE from 1 cm³/rev to 28 cm³/rev and peak pressure up to 300 bar.

► See brochure 2.902.6 – Pump Overview
See brochure 2.902.1.0 – Motor Specification

Diesel Filtration



The HDP 600 BC with integrated pump is a modern system for diesel pre-filtration. It has a two-stage water separation system and outstanding solid particle filtration characteristics. As air can also be a major problem in fuel supply, an electric pump has been integrated. The pump can be used both for fuel supply during machine operation and for offline filtration during downtime.

Advantages

- Fuel system is vented via integrated electric pump in the bypass
- Booster function improves start-up performance (cold starts in particular)
- Reduction of pressure in the machine's low pressure pump
- Protects against microbial growth in the filter, thanks to innovative Biomicron® filter media technology which combats diesel bug in the filter element (optional); of particular interest for seasonal machines
- Long service life, as pump is brushless
- Flexible connection options

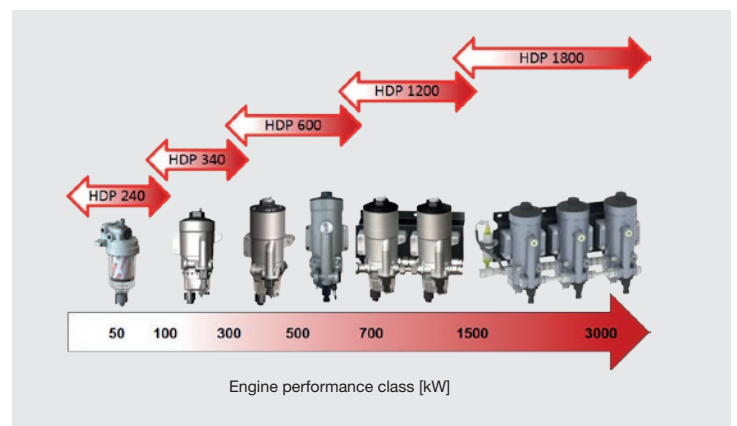

► See brochure 7.125 – Diesel PreCare

Filtration, Air Separation and Tank Optimisation

Filtration



Our broad filter range offers inline filters (LF, MDF, DF) with various pressure ranges and materials in addition to filling/breather filters (ELF) for the hydraulic tanks. We also have a broad range of in-tank return line filters (RF) and return line suction filters (RKM). Specially designed in-tank return elements (RKB) offer good distribution of oil flow in the tank, highly effective air separation and thus a reduction in the size of the hydraulic tank.

The filters can also be used in potentially explosive atmospheres (ATEX).

Advantages

- High level of operating safety thanks to first class filtration
- Protection of system components
- Element is easy to change and filter housing is easy to install
- Low operating costs thanks to low pressure drops across the filter and filter element
- Improvement in operating safety through the use of filter clogging indicators
- Brand labelling to protect the spare parts business
- Tank/filter complete systems, optimised for component protection, system cleanliness and venting
- Ultra-modern laboratory and test rig technology

Hydraulic load cycle test (HLCT)

Filter performance data measured in accordance with practical flow conditions (dynamic flow) rather than static multi-pass test to DIN 16889.

The practical flow rate can, for example, be measured at the wheel loader and then simulated on a 1:1 basis on the test bench.



Tank and filtration systems

A comprehensive range of hydraulic and breather filters equipped with elements made from high-quality materials provide a high level of operating safety and long maintenance intervals. For example:

Return/return-suction filtration

Using the RFM and RKM filters (with optional temperature bypass valves integrated into the head), tank-mounted or tank-integrated filters

Supply circuit filtration

With inline filter LPF and LPFP

Pressure oil filtration

With inline filter MFM, HFM, DF

Transmission oil filtration

Suction filter for transmission and hydraulic oil

Removal of coarse particles

With inline filter ILF

Air filtration

With breather filters BF, ELF, ELFL, BDE.

Wide standard range of products, with optional duo valve for tank pre-tension, anti-splash protection possible, version with air drying function, air filter systems for motors

Filter clogging indicators (CI)

For improvement of operating safety and, if applicable, display of maintenance intervals

Brand labelling to protect the spare parts business

Marking of the filter elements to improve product identification and to ensure spare element availability

Tank filter solutions from one supplier

Complete systems ready for installation, optimised in terms of component protection, system cleanliness and ventilation

Filtration solution for AdBlue® and SCR cooling

- ▶ See catalogue 70.000 – Fluid Filters
- ▶ See brochure 10.777 – Filtration and Fluid Care

Return Line Filter



Maximum air separation in a hydraulic system can only be achieved with the combination of an optimised filter and tank.

Accordingly, our standard series for optimised air separation provides the best possible foundation for protecting the hydraulic system from excess air in the oil and the problems that this causes.

Flow passes from inside to out in all filters in the series. This means that the filters are the main factor involved in calming the flow to the tank. The filter's larger outlet

surface area makes the oil

flow out of the filter at a much slower speed. This gives the air bubbles in the oil more time to rise to the surface slowly and evenly, helping to calm the oil level in the tank.

RKT: Return Line Kit – Top

- Integrated into the tank
- Flow enters from top
- High variability in connections
- Optional cover
- Optional magnetic core
- Optional quality protection

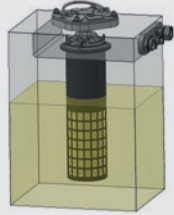

RKB: Return Line Kit – Bottom

- Integrated into the tank
- Flow enters from bottom
- Bypass valve integrated into element
- High variability in connections
- Optional non-return valve
- Optional quality protection

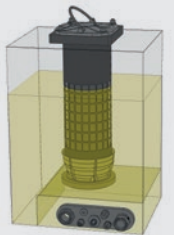

RFT: Return Line Filter – Top

- Complete filter solution
- Flow enters from top
- Filter head version
- Bypass valve integrated into element
- Optional magnetic core
- Optional quality protection

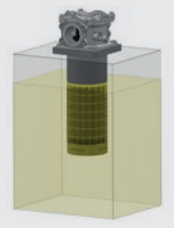

RFB: Return Line Filter – Bottom

- Complete filter solution
- Flow enters from bottom (or side)
- Bypass valve on cover and element (split)
- Optional non-return valve
- Optional quality protection

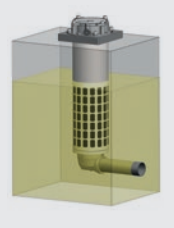

▶ See brochure 7.422 – Return Line Filters

Hydraulic Tanks

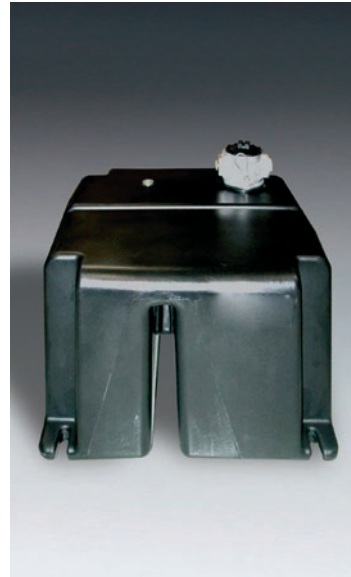

Unlike welded steel tanks, customised plastic tanks – which are a complete solution including breather and return line filters and fill-level and temperature indicators – are mainly used when installation space is extremely limited and very lightweight construction is required.

- **Improved technical cleanliness**
since plastic tanks are very clean following production.
- **Air from oil**
Special tank geometry allows quick and optimal air separation.
- **Improved use of existing installation space**
due to optimised design (complex, curved designs available). In addition to the combination of filter and tank, HYDAC also supplies filter-cooler-tank combinations from a single supplier (see page 20).
- **Inexpensive**
The costs depend on tank volume rather than design complexity.
- **Clean tank surface**
due to integral baffle designed to prevent fluid spill from the breather filter onto the tank.
- **Element does not block**
due to dry air filter element and partial cleaning whenever air is expelled – dust is purged from the filter material.

▶ See brochure 7.020 – Mobile Machinery Update

Additional Solutions

Accessories

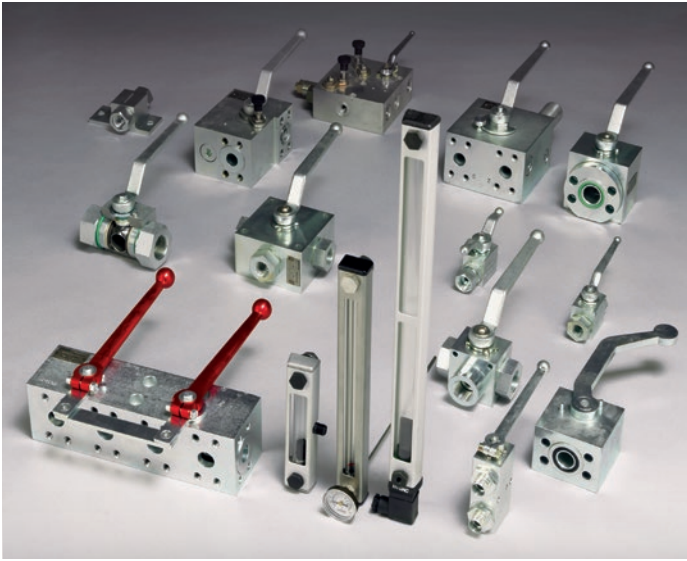

For the completion of hydraulic systems

- Pipe fittings and ball valves (high pressure, low pressure, coaxial valves, standard and special solutions)
- HY-ROS mounting clamps for hydraulic hoses and lines, pipes and cables
- Clamping bands for mounting hydraulic, air and other reservoirs in round or rectangular shape
- Special clamps, e.g. for particle filters (clamping band and console)
- Fluid level gauges FSA and fluid level sensors FSK along with temperature switches TS

Advantages

HYDAC Accessories is your competent partner for any modifications and special solutions, especially when custom jobs are required because standard parts are unsuitable. HYDAC's in-house engineering, coupled with our multidisciplinary approach and worldwide know-how, guarantees state-of-the-art technology and rapid development times.

HYDAC Accessories provides the final perfect touch to your machine with a broad range of standard and special components which are also available in stainless steel.

▶ See catalogue 61.000 – Accessories

Cylinder Systems

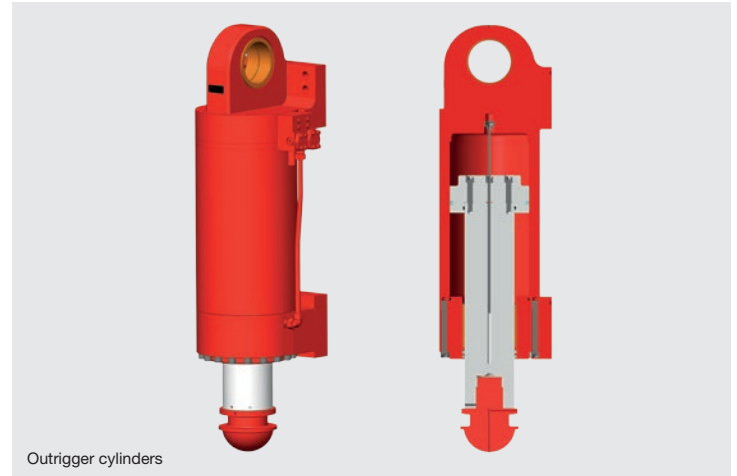

Outrigger cylinders

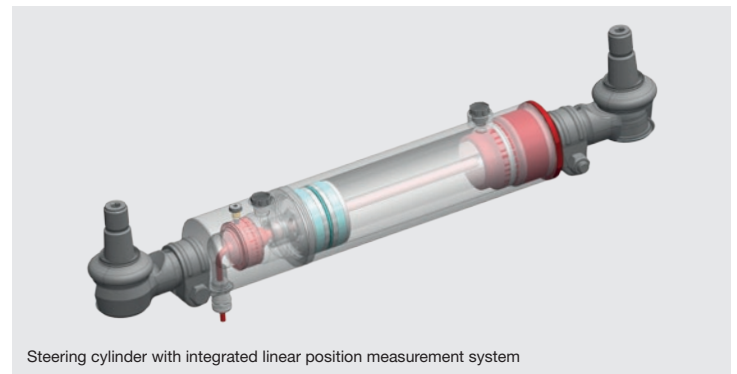

Steering cylinder with integrated linear position measurement system

Our freely configurable cylinder systems are available for both static and highly dynamic applications.

Our product range includes:

- Special cylinder with integrated sensors, special coating or end cushioning
- Special suspension cylinders (low-friction design)
- Steering cylinder
- Locking and clamping cylinders
- Differential and telescopic cylinders
- Cylinders with integrated piston accumulator

Advantages

Our in-house Service Center provides comprehensive customer service. We support you with the configuring, assembly, commissioning and maintenance of your system. Right from the development stage, we work closely with our customers.

With our many years of experience in cylinder construction, we are able to develop optimum cylinder solutions for our customers' applications. FE simulations and fatigue strength calculations also come under our Engineering Standard.

▶ See brochure HS-D 10.102 – Cylinders and Cylinder Systems for Mobile Hydraulics

Fluid Condition Monitoring and Fluid Conditioning



FluidMonitoring module FMM



HYDACLAB® HLB 1400,
ContaminationSensor CS 1000,
AquaSensor AS 1000 / AS 3000



SensorMonitoring Unit SMU 1200

For a system to be fully efficient and reliable, it needs a sophisticated filtration strategy and continuous online monitoring, combined with temperature-controlled cooling. Only a holistic approach can permanently improve the state of the used fluids and decrease the operating costs (cost reductions of up to 30% are not uncommon). Accordingly, HYDAC provides the complete package of condition monitoring, filters, coolers and systems for detecting fluid stresses and rectifying them. You can plan service work in advance, avoid unnecessary costs for maintenance and repair and benefit from optimised costs for system maintenance.

One product that prevents fluid stress is the Optimicron® element with Stat-Free® or even Stat-X® technology for the prevention of electrostatic discharge.

If oils are subjected to electrostatic discharge, they age more quickly and in the long run systems become damaged. The VarnishMitigation Unit (VMU), which removes oil degradation products from the fluid, and the CM-Expert, used for online monitoring of production systems, also increase the service life of the fluids.

► See catalogue 180.000 – Electronic

Service Tools



FCU 1310



OF 7 CM



HMG 4000

- Tools for documenting the oil cleanliness and water saturation, e.g. after service work
- Bypass filter optimises existing hydraulics and lubricating systems by removing oil degradation products, particles and water

► See catalogue 79.000 – Filter Systems
See catalogue 180.000 – Electronic

Additional Solutions

Technical Cleanliness



CTU 1000



CTM-SC

More efficient components and systems, increasing warranty claims and the reduction in start-up breakdowns are steadily driving up the demands for cleanliness management and cleanliness monitoring of production components. Tracing the source of damaging particles on surfaces which are in contact with the fluid, the removal and appropriate analysis of these particles are areas where HYDAC does extensive research within the framework of technical cleanliness.

The CTU (ContaminationTest Unit) and CTM (ContaminationTest Module) extraction units, which have been specially developed to analyse technical cleanliness, have numerous applications in a wide variety of industries.

Individually designed adaptations for carrying out cleanliness analyses provide solutions from a single source.

ContaminationTest Unit CTU

The ContaminationTest Unit CTU 1000 series is designed to analyse the technical cleanliness of components and systems in accordance with guideline VDA 19 (ISO 16232 or ISO 18413).

ContaminationTest Module CTM

The ContaminationTest Module CTM is a modular system designed to analyse the technical cleanliness of components.

The CTM series consists of different modules:

- Supply Module CTM-SC (Supply and Control):
Module for fluid supply, control and data storage.
- Extraction Module CTM-EB:
The modules vary according to the size/model and extraction process. They feature four types of extraction in different combinations.
- Extraction Flushing CTM-EF:
By adapting to the geometry of the components being sampled, the module can be used for flushing components in contact with fluid.
- Fluid Analyzer CTM-FA:
Module for determining the particle count according to ISO 16232 by conditioning the fluid and evaluating via visual particle counter.

▶ See catalogue 79.000 – Filter Systems

HYDAC KineSys Electro-Cylinders for Mobile Applications

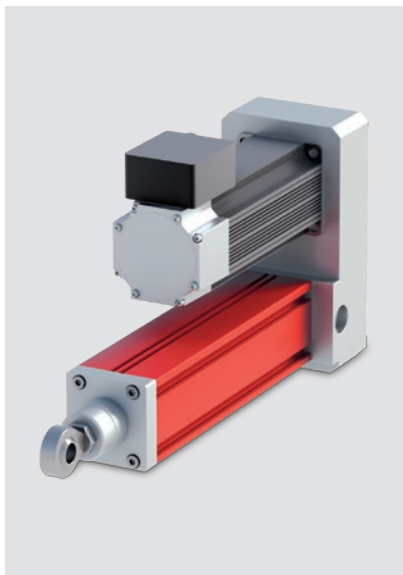

Description

The HEZ KineSys electro-cylinders in U design are suitable for use in mobile machines and devices. The compact, closed housing provides protection from environmental influences. The selectable operation voltages of the motors provide a wide range of possible automotive and industrial uses. Furthermore, it is possible to integrate a linear position measurement system.

Product advantages

- Compact design
- Maintenance-free
- Limit switches can be attached to cylinder
- A linear position measurement system can be integrated
- Plug & play-ready solution
- Positioning force up to 10 kN dynamic, 18 kN static
- Protection class up to IP 69 K
- Operation voltage 12, 24 and 36 V DC/230 and 400 V AC

Trends in Traction Hydraulics and Work Hydraulics in Mobile Machines

Digitalisation



- Connectivity/ Telematics
- Smart Sensors
- Smart Service/ Predictive Maintenance

Assistance Systems/Automation

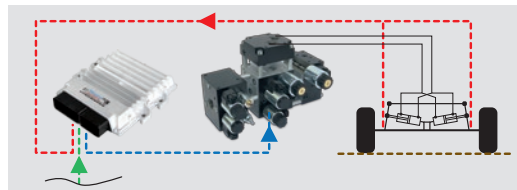

- Increasing Use of Electronics/ Upgrading
- Electro-Hydraulic Steering
- User-Friendliness/ Safety
- Autonomous Driving

E-Mobility

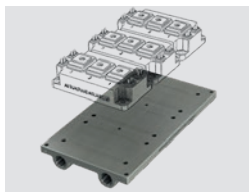
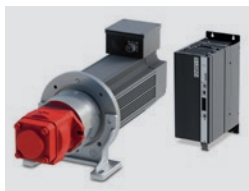
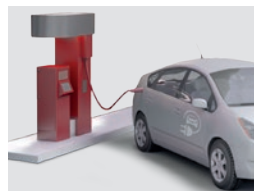

- Infrastructure/ Charging Stations
- Decentralised Drives
- Energy-efficient Hydraulics
- Battery/ Thermal Management

Sustainability

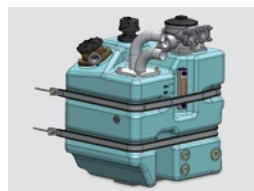

- Hybridisation/ Downsizing
- Hydraulic Start-Stop Operation
- Tank Optimisation
- Filter-Cooler-Tank Combinations
- Fuel Filtration



Accumulator Technology 30,000



Filter Technology 70,000



Control Technology 18,500



Filter Systems 79,000



Compact Hydraulics 53,000



Accessories 61,000







Electronics 180,000

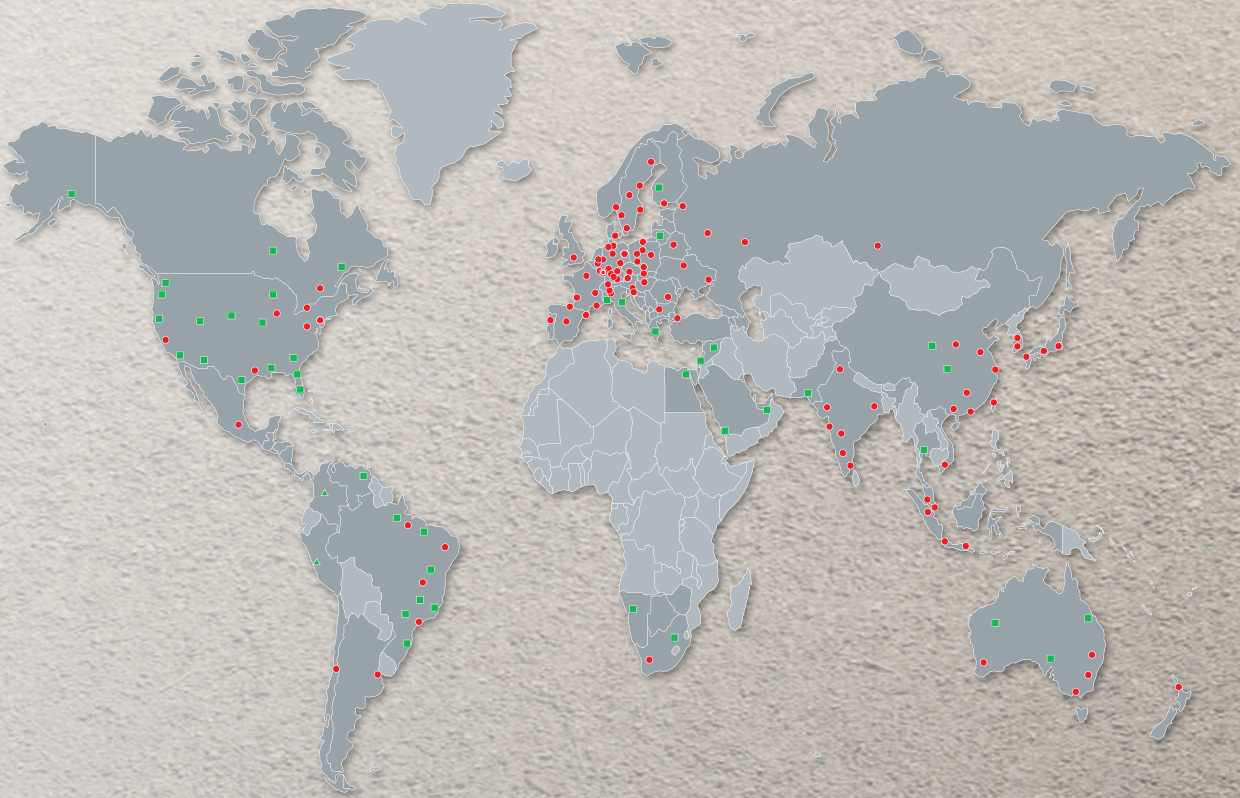

Cooling Systems 57,000

Global Presence. Local Expertise. www.hydac.com



-  HYDAC Headquarters
-  HYDAC Companies
-  HYDAC Sales and Service Partners
-  Free Sales Partners

HYDAC INTERNATIONAL

HYDAC International GmbH

Industriegebiet
66280 Sulzbach/Saar
Germany

Tel.: +49 6897 509-01
Fax: +49 6897 509-577

E-mail: info@hydac.com
Internet: www.hydac.com